

# OBM-4K Quad Series

Professional Video 4K Quad-Split Monitors



## Operational Instructions

OBM-U170Q

OBM-U240Q

OBM-U310Q

OBM-U420Q



[www.postium.com](http://www.postium.com)

## **Table of Contents**

1. Precaution	3
2. Main Features	5
3. Location and Function of Parts and Controls	
<i>Front Panel</i>	6
<i>Rear Panel</i>	8
4. Using the Menu	10
5. Adjustment Using the Menu	11
6. OSD Menu Operations	
<i>Status Menu</i>	14
<i>Color Temp/Color Space/Gamma Menu/</i>	
<i>Input Range Menu</i>	15
<i>Camera Assist Menu</i>	19
<i>User Configuration Menu</i>	20
<i>Remote Menu</i>	24
<i>Security Menu</i>	27
7. Scan Mode Image	28
8. Connecting the SDI Signals	29
9. Available Signal Formats	30
10. Key Functions	32
11. Product Specifications	
<i>OBM-U170Q</i>	39
<i>OBM-U240Q</i>	40
<i>OBM-U310Q</i>	41
<i>OBM-U420Q</i>	42

# 1. Precaution

Always use set voltage.

AC 100 ~ 230V, 50/60Hz

DC 24V(OBM-U170Q, OBM-U240Q, OBM-U310Q), U420Q cannot be connected to DC.

All these instructions should be read and understood before operating the unit.

If liquid is spilled on or impacts this product, please disconnect the product immediately and seek professional help before continued use.

Unplug the product from the wall outlet if it is not to be used for several days or more.

Keep the product in a well-ventilated place to prevent overheating.

Do not install the product near any heat-generating equipment. Also, keep the product out of direct sunlight or dusty areas.

Protect the power cord from being walked on or pinched particularly at plugs, convenience receptacles, and the point where they exit from the apparatus.

When using other DC 24V(OBM-U170Q, OBM-U240Q, OBM-U310Q) adapters instead of the standard adapter provided by the manufacturer, please check the proper load capacity or current capacity and use an adapter with stable voltage.

Do not overload AC outlets or extension cords. Overloading can cause fire or electric shock.

A very small proportion of pixels may be stuck, either always off (black), always on (red, green, or blue), or flashing. In addition, over a long period of use, because of the physical characteristics of the liquid crystal display, such stuck pixels may appear spontaneously. These problems are not a malfunction.

If a fixed picture such as a frame of a divided picture or time code, or a still picture is displayed for a long time, an image may remain on the screen and be superimposed as a ghosting image.

The permanent burn-in may occur for LCD panel if still images are displayed in the same position on the screen continuously, or repeatedly over extended periods.

To reduce the risk of burn-in,

- a. Turn off the character displays.
- b. Turn off the power when not in use.
- c. Turn off the power if the monitor is not to be used for a prolonged period of time.

Do not attempt to service the product yourself. Removing covers can expose you to high voltage and other dangerous conditions. Request a qualified service person to perform servicing.

When the product needs replacement parts, make sure that the service person uses replacement parts specified by the manufacturer, or those with the same characteristics and performance as the original parts. Use of unauthorized parts may result in fire, electric shock and/or other danger.

Only clean the product with a noncommercial, mild and neutral detergent.

Do not throw away the carton and packing materials. When transporting the product, make use of its original packaging for safer carriage.

### FCC (Federal Communications Commission)

This equipment has been tested and found to comply with the limits for class A digital device, pursuant to part 15 of the FCC Rules. These limits are designed to provide reasonable protection against harmful interference when the equipment is operated in a commercial environment. This equipment generates, uses, and can radiate radio frequency energy, and if not installed and used in accordance with the instruction manual, may cause harmful interference to radio communications. Operation of this equipment in a residential area is likely to cause harmful interference in which case the user will be required to correct the interference at his own expense.

**⚠ Warning!!** : Changes or modifications not expressly approved by the manufacturer could void the user's authority to operate the equipment.

### Disposal of Old Electrical & Electronic Equipment

(Applicable in the European Union and other European countries with separate collection systems)



This symbol on the product or on its packing indicates that this product shall not be treated as household waste. Instead it shall be handed over to the applicable collection point for the recycling of electrical and electronic equipment. By ensuring this product is disposed of correctly, you will help prevent potential negative consequence for the environment and human health, which could otherwise be caused by inappropriate waste handling of this product. The recycling of materials will help to conserve natural resources.

## 2. Main Features

### 4K professional monitor OBM-U\*\*\*Q Series unit has the following features:

#### -Versatile HD/3G/4K Input Capability

This monitor is equipped with standard 12G-SDI input interface(x4) and support 4K 2-sample interleave signals and 4K square division signals and Quad split and Side by side split.

This monitor accepts up to 3840/2160 23.98/24/25/29.97/30/50/59.94/60p and 4096x2160 23.98/24/25/29.97/30/50/59.94/60p

- Supporting 12G/6G-SDI(4K) 4 Channel
- Quad Link Square Division
- Quad Link 2 Sample Interleave (2SI)
- Quad Split
- Side by Side Split(PBP)
- HDR(High Dynamic Range) display supporting PQ EOTF(ST 2084), Hybrid Log Gamma, S-Log3
- 3D-LUT for Accurate Color Reproduction
- Wide Color Space Supporting ITU-R BT.709, SMPTE-C, EBU, Native, DCI-P3, ITU-R BT.2020
- Camera Log Conversion
- Custom 3D LUT file import through USB
- Gamma Selection (1.0 ~ 3.0)
- ITU-R BT.1886 Gamma
- Color Temperature(3200K, 5500K, 6500K, 9300K, USER 1/2/3, P3-D65)
- Monitor Update/Control via Ethernet, USB / RS-422
- Focus Assist
- False Color (Zebra, False Color ARRI, False Color Variable)(Single mode)
- Waveform, VectorScope (Wave+Vector : Single mode)
- HDR Waveform
- Firmware Update via USB Flash Memory
- Various Markers (EBU, 4:3, 16:9, 1.85:1, 2.35:1, Variable, Custom etc.)
- Zero Scan / 1:1 Scan (Single mode)
- Time Code Display
- De-embedded 8~16ch Audio Level Meter
- SFP optical connector
- White Internal Patterns Display for Color Test (Black ~ 100%, Color Bar)
- Remote Control via GPI(RJ-45) Port
- H/V Delay(only HD format)
- Blue/Mono
- 3 Color TALLY Lamp
- Rack & VESA Mount (Option)
- System Data Copy
- Various Preset Mode
- Key Lock & Password Lock
- HDR Auto Setting(Single mode)
- HDMI 2.0 Support
- Aspect(Single mode)
- Freeze

## 3. Location and Function of Parts and Controls

### Front Panel (OBM-U170Q)

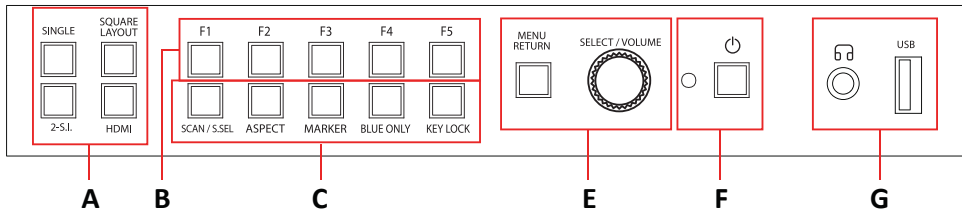

### Front Panel (OBM-U240Q / U310Q / U420Q)

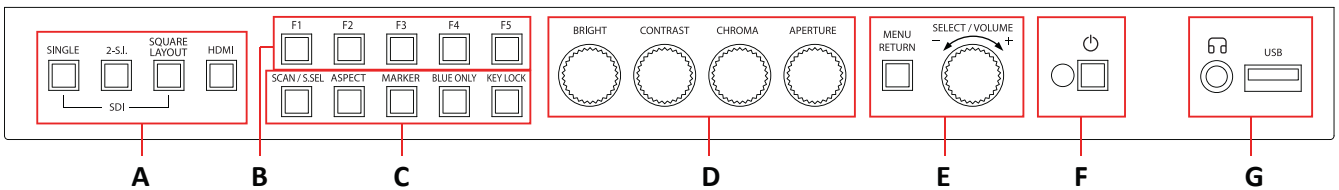

#### A : Input select Buttons/Lamp

Press to monitor the signal input to each connector.

##### [SINGLE] Button/Lamp

- Press the button to select SDI input or SFP input for one channel.
- Mode changes in the order of [12G SDI-1], [12G SDI-2], [3G SDI-3], [3G SDI-4], ([SFP-1],[SFP-2])
- \* SFP input is set deactivated in the default setting. Change the menu setting to activate SFP input.  
MENU > User Configuration > [2/7] > SFP Enable > Enable

\*\*How to make a quick input change : When you push [SINGLE] button and the current input indicator is displayed, turn the [SELECT/VOLUME] knob to select another input and push the knob, then you can go to another input directly.

##### [2-S.I.] Button/Lamp

- Press the button to select 2-SAMPLE Interleave SDI input signal through two or four SDI input connectors.
- Mode changes in the order of [Dual-Link 2-S.I.], [Quad-Link 2-S.I.]. [Dual-Link 2-S.I.(SFP)]

##### [SQUARE/LAYOUT] Button/Lamp

- Press the button to select [Quad-Link Square],[Quad],[PBP] modes.

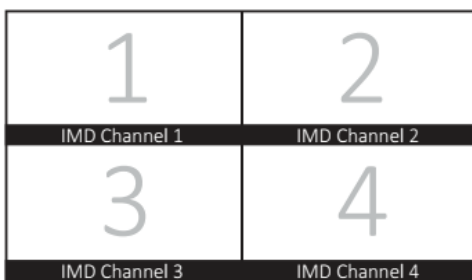

Quad

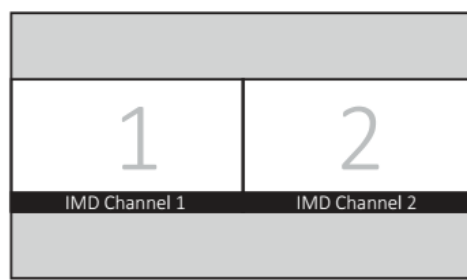

PBP

##### [HDMI] Button/Lamp

- Press the button to select HDMI input.

#### B : F1 ~ F5 Button/Lamp

Press to adjust or turn on/off the assigned function.

The following functions are assigned at the factory.

- [F1]: HDMI to Screen 4(2) / (4:quad, 2:PBP)
- [F2]: H/V Delay
- [F3]: Color Temp
- [F4]: Audio Level Meter
- [F5]: Time Code

**C : Function Button/Lamp**

Press to adjust or turn/off each function.

**[SCAN/S.SEL] Button**

- Press the button to adjust the scan mode. (Zero Scan, 1:1 Scan). (single mode)
- Press this button to select the channel which you want to adjust the settings of.
- The channel is selected in the order of Screen 1 > Screen 2 > Screen 3 > Screen 4 > All Screen
- The settings which can be adjusted to each Screen are Color Temp., R/G/B Gain, R/G/B Bias, Color Space, Gamma,

**[ASPECT] Button**

- Press the button to select the Aspect Ratio of the signal.
- Mode changes in the order of [16:9], [4:3], [2.35:1], [1.85:1], [15:9], [16:10], [AUTO].

**[MARKER] Button**- Press the button to activate and deactivate the Marker.**[BLUE ONLY] Button**

- Press the button to activate and deactivate the Blue Only function.
- You may remove R(red) and G(green) from the input signal and display the screen only with B(blue) signal. This function is convenient to adjust Chroma and Phase and to observe the signal noise.
- The button may be pressed twice to change the screen to MONO mode. (This mode uses only Luminance value.)

**[KEY LOCK] Button**- Press the button to lock all buttons except Power/Menu.**D : Rotary encoder****[BRIGHT] knob**

Press this knob to display the adjustment screen and adjust the picture brightness. Press again to hide the adjustment screen. Turn the knob right to increase the brightness and turn left to decrease it.

You can adjust the different value to each Channel by selecting the Channel using [SCAN/S.SEL] button.

**[CONTRAST] knob**

Press this knob to display the adjustment screen and adjust the picture contrast. Press again to hide the adjustment screen. Turn the knob right to increase the contrast and turn left to decrease it.

You can adjust the different value to each Channel by selecting the Channel using [SCAN/S.SEL] button.

**[CHROMA] knob**

Press this knob to display the adjustment screen and adjust the color intensity.

Press again to hide the adjustment screen. Turn the knob right to increase the color intensity and turn left to decrease it.

You can adjust the different value to each Channel by selecting the Channel using [SCAN/S.SEL] button.

**[APERTURE] knob**

Press this knob to display the adjustment screen and adjust the picture sharpness. Press again to hide the adjustment screen.

Turn the knob right to make the picture sharper and turn it left to make the picture softer.

**E : Menu Operation Buttons**

Displays or sets the on-screen menu.

**[MENU/RETURN]**

- Activates and deactivates the display of the Main Menu.
- When the on-screen menu is not displayed, if this button is pressed the main menu is display. When the menu is displayed, press the button to return to the previous menu.

**[SELECT/VOLUME] knob (Menu selection control)**

- When the menu is displayed, turn the knob to select a menu item or setting value, and then press the knob to confirm the setting.
- If the menu is not displayed and this knob is pressed, the adjustment screen of [VOLUME] is displayed to adjust the audio volume.
- Press this knob to change the modes in the order of [Focus Frequency] [Zebra Level] [Line Position] [Variable Marker] and adjust each mode's value.
  - [Focus Frequency]: When Focus Assist function is activated, this mode is displayed.
  - [Zebra Level]: When Zebra function is activated, this mode is displayed.
  - [Line Position]: When WFM/Vector function and Line Select function is activated, this mode is displayed.
  - [Variable Marker]: When Marker function is activated and Aspect Marker is set Variable, this mode is displayed.

## F : ⏻ (Standby) Switch and Indicator

- Press to turn the power on when this monitor is in standby mode. After being turned on, the monitor performs initialization and the indicator flashes in green.
- Press the switch again for a second to set the monitor in standby mode. Then, the indicator flashes in orange and then turns red. The indicator in orange means that the monitor goes into the standby mode. When the indicator flashes in orange, this button doesn't work.

## G : 🎧 (headphone) Jack and USB Connector

### Headphone Jack

- The audio signal which is selected using the input select button is output in stereo sound form speakers.
- When SDI signals are input, the audio signals of the channels selected with SDI Audio Setting in the User Configuration menu are output.
- When the headphone is connected to the 🎧 jack, audio signals will not be output from speakers.

### [USB] Connector

- To update CPU, GPU, FPGA program.
- To connect the monitor with the Color Calibration program provided by the manufacturer and perform the color calibration.
- To connect the monitor with the control program provided by the manufacturer and control functions remotely.
- To input the custom 3D LUT file (\*.cube, 32^3, 33^3, 64^3 and 65^3).

## Rear Panel (OBM-U170Q / OBM-U240Q / U310Q), (U420Q cannot be connected to DC)

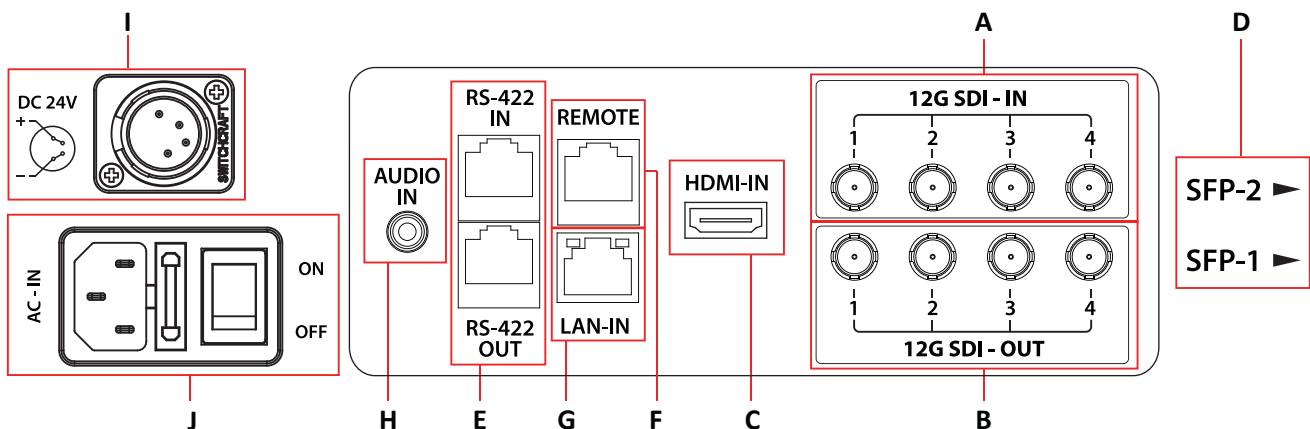

### A : SDI IN (SDI Input) connectors (BNC)

Input connectors for SDI signals. For details, see “Connecting the SDI Signals”

### B : SDI OUT (SDI Output) connectors (BNC)

Output connectors for SDI signals.

Each connector outputs the signal which is input to the corresponding SDI IN connector.

\*\*Note - Output is activated only when the power is on. Output is not activated in standby mode.

### C : HDMI input connectors

Input connectors for HDMI signals.

- For an HDMI cable, High Speed HDMI Cable with the cable type logo or HDMI 2.0 Cable is recommended.
- When inputting 4K resolution(3840 x 2160 or 4096 x 2160) signal, use a cable of 3m or less.

### D : SFP Input connector

Input connector for SFP optical signal.



### E : SERIAL REMOTE IN/OUT connector (RJ-45)

Used for the future function expansion.

Connects the monitor to control the program provided by the manufacturer by using RS-422/485 communication or the external UMD(IMD) equipment and controls the monitor.

### F : PARALLEL REMOTE connector(RJ-45, 8-pin)

Forms a parallel switch and controls the monitor externally.

**\*\*Note** - For safety, do not connect the connector for peripheral device wiring that might have excessive voltage to this port. Follow the instructions about this port.

[Pin Assignment]

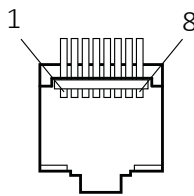

Pin Number	Function
1	12G SDI-1
2	12G SDI-2
3	12G SDI-3
4	12G SDI-4
5	Dual-Link 2-S.I.
6	Quad-Link 2-S.I.
7	Power
8	GND

Functions can be changed in [Remote] section of the menu.

### G : LAN(10/100) IN/OUT connector

Used for the future function expansion.

Connects to the LAN (10/100) connector of the network by using 10BASE-T/100BASE-TX LAN cable.

A daisy chain connection using the LAN input/output connectors enables the control of multiple monitors in sequence.

### H : AUDIO IN connector (Stereo mini jack)

Connector for analog audio input.

Analog input can be selected with SDI Audio Setting in User Configuration menu.

### I : DC IN terminal

Connects the DC power supply to the monitor.

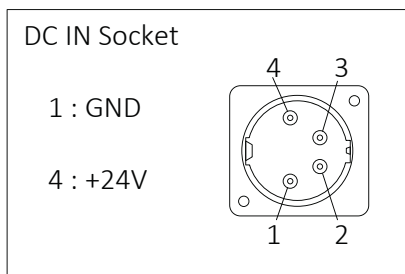

- OBM-U170Q : 12V/24V
- OBM-U240Q : 12V/24V
- OBM-U310Q : 24V
- OBM-U420Q : AC Only

### J : AC IN terminal

AC power input connector.

Connects the provided AC power cord.(~AC IN 250V T3. 15A)

## 4. Using the Menu

This monitor is equipped with an OSD menu to make various adjustments and settings such as picture control, input setting, set setting change, etc.

### 1. Press the MENU button.

The menu appears.

The menu presently selected is shown in gray.

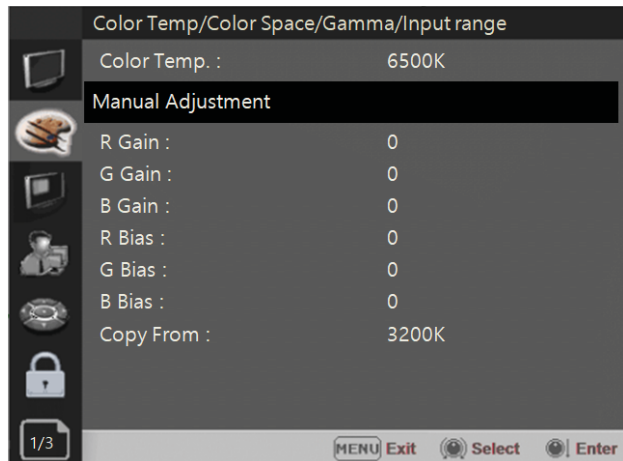

### 2. Turn SELECT/VOLUME knob to select a menu, then press the knob.

The menu icon presently selected is shown highlighted.

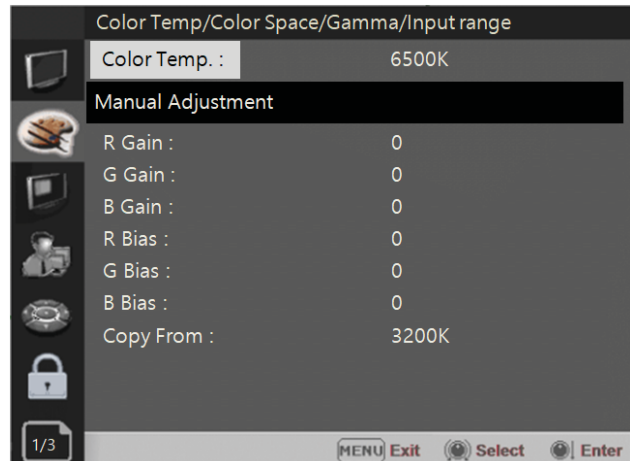

### 3. Select an item.

Turn SELECT/VOLUME knob to select the item, then press the knob.

The item to be changed is shown highlighted, and the sub menu is displayed on the right.

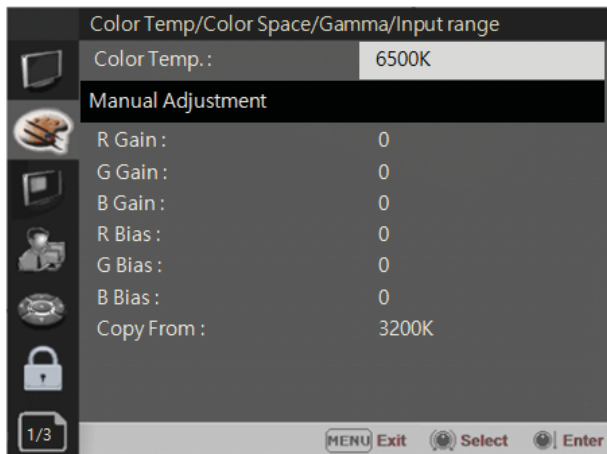

### 4. Make the setting or adjustment on an item.

#### **How to change the adjustment level:**

To increase the level, turn the SELECT/VOLUME knob right.

To decrease the level, turn the SELECT/VOLUME knob left.

#### **How to change the setting:**

Turn the SELECT/VOLUME knob to change the setting, then press the knob to confirm the setting.

**\*\*Note** - The item displayed in gray cannot be accessed. The item is accessible if it is displayed in white.

#### **To return the display to the previous screen:**

Press the MENU button.

#### **To clear the menu:**

Press the MENU button.

## 5. Adjustment Using the Menus

The OSD menu of this monitor consists of the following items.



### Status menu (To indicate the current settings)

- Format
- Color Temp
- Brightness
- Contrast
- Chroma
- Aperture
- Color Space
- Gamma
  
- User Preset
- RGB Range
- WFM/Vector
- Audio Level Meter
- Focus Assist
- Time Code
- Volume
  
- SDI Input
- SDI Payload ID
- Identifier
- Sampling
- Picture Rate
- Scanning Method
- Bit Depth
- Link Assignment
- Transfer Characteristic
- Colorimetry
  
- Model Name
- Serial Number
- Board Version
- Operation Time
- Last Calibration Time
- Board Temp



### Color Temp./Color Space/Gamma menu

- Color Temp
- Manual Adjustment
  - R Gain
  - G Gain
  - B Gain
  - R Bias
  - G Bias
  - B Bias
  - Copy From
- Color Space
- HDR-EOTF
  - Type
- Gamma
- Backlight
- Camera Log
  - Default Log Sel.
  - User Log Sel.
- RGB/YCC Range
- HDR Auto Setting



### Camera Assist menu

- Zebra & False Color Setting
  - Zebra & False Color
    - Zebra Level Adj.
    - Zebra Range
    - Variable White Clipping
    - Variable Pink Level
    - Variable Green Level
    - Variable Black Clipping
  - False Color Comparison
    - Wipe Position
- Focus Assist Setting
  - Focus Assist
    - Color
    - Frequency



## User Configuration menu

User Preset Setting

| Load

| Save

Function Button Setting

| F1 Button

| F2 Button

| F3 Button

| F4 Button

| F5 Button

Input Setting

| 3G Signal Format

| SFP Enable

| 12G Image Division

| Image Division & Link

Audio Delay Setting

| Audio Delay(Lip Sync)

Speaker Out / Audio Level Meter Setting

| SDI L-Speaker Out

| SDI R-Speaker Out

| HDMI L/R Speaker Out

| Audio Level Meter

| | Display

| | Reference

| | Size/Transparency

| | Peak Hold Time

Marker Setting 1/2

| Marker

| | Aspect Marker

| | | Variable Aspect

| | Center Marker

| | Area Marker  Color

| | Aspect Mat

| | Fit

| | Thickness

Marker Setting 2/2

| Custom H1

| Custom H2

| Custom V1

| Custom V2

WFM/Vector Setting

| WFM/Vector

| | Type

| | Intensity

| | Transparency

| | Color

| | Line Select

| | | Line Position

| | Position

System Setting

| Internal Signal

| Key LED

| OSD Time

| OSD position

| System Data

| Time Code



## Remote menu

Parallel Remote

- 1 Pin
- 2 Pin
- 3 Pin
- 4 Pin
- 5 Pin
- 6 Pin
- 7 Pin
- 8 Pin

Monitor ID

In-Monitor Display Setting

- IMD Type
- User Text
- Transparency
- Text Color
- L-Tally Color
- R-Tally Color

Network Setting

DHCP

IP Address

Subnet Mask

Gateway

Port No.



## Security Setting

Key Lock

Password

User Parameter Lock

Change Password

## 6. OSD Menu Operations

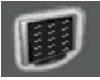

### Status Menu

The Status menu displays the current status of the monitor. The following items are displayed.

#### Page 1/4

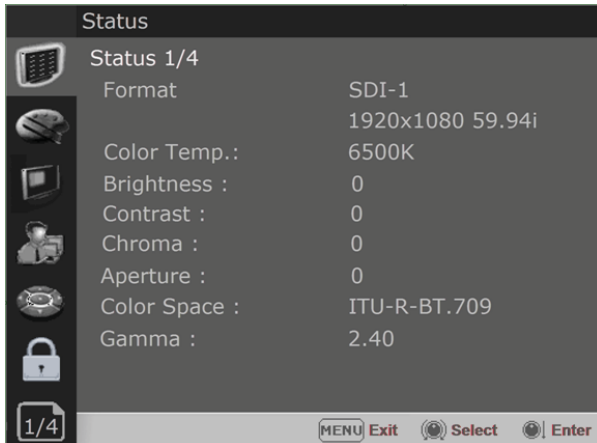

- Format
- Color Temp
- Brightness
- Contrast
- Chroma
- Aperture
- Color Space
- Gamma

#### Page 2/4

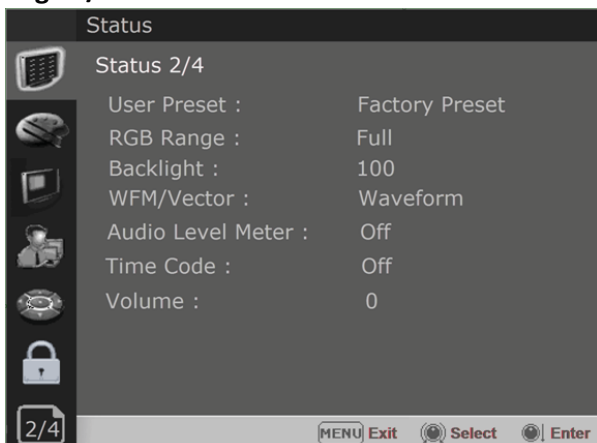

- User Preset
- RGB Range
- Back Light
- WFM/Vector
- Audio Level Meter
- Time Code
- Volume

#### Page 3/4

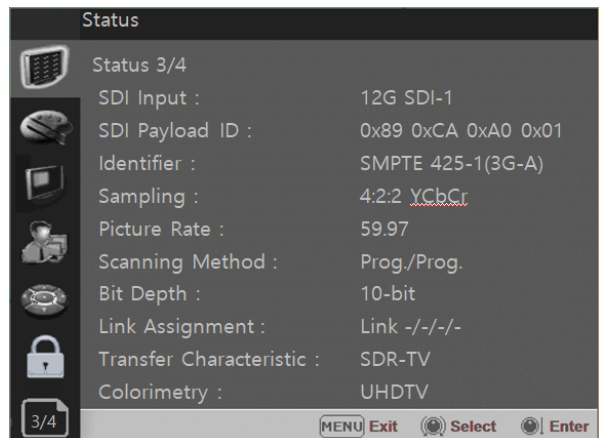

- SDI Input
- SDI Payload ID
- Identifier
- Sampling
- Picture Rate
- Scanning Method
- Bit Depth
- Link Assignment
- Transfer characteristics
- Colorimetry

\*\*\* When the SDI signal is connected, these items are displayed.

#### Page 4/4

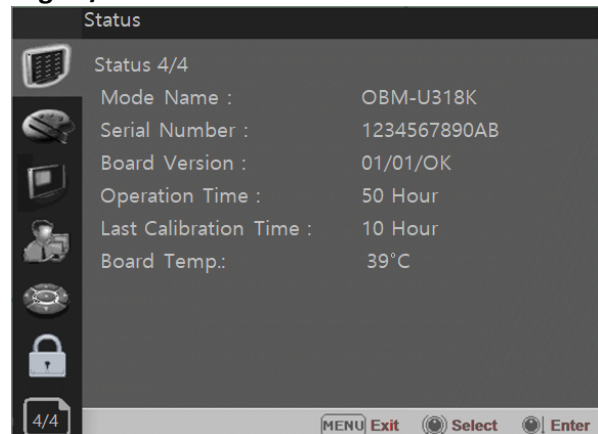

- Model Name
- Serial Number
- Board Version
- Operation Time
- Last Calibration Time
- Board Temp.



## Color Temp/Color Space/Gamma Menu/Input Range Menu

These menus are used for adjusting or setting the color temperature, color space or gamma of the picture.

### Page 1/3

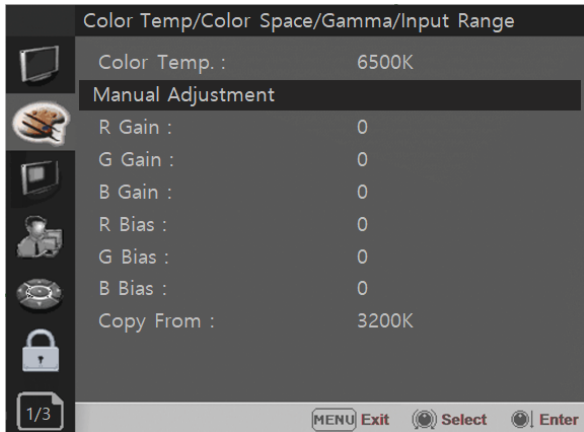

#### Color Temp.

- Selects the color temperature from among [3200K], [5500K], [6500K], [9300K], [User1], [User2], [User3].
- The different setting value can be adjusted to each Screen.

#### \*\*Note

If Color Space is set to [DCI-P3], selects the color temperature from among [P3-D65][User1] [User2] [User3]..

#### R/G/B Gain

- Displays the R/G/B Gain of the current Color Temperature.

#### Manual Adjustment

- If you set the Color Temp. to User 1/2/3, the item is changed from black to white, which enables you to adjust the color temperature.

#### R/G/B Gain/Bias

- Adjusts the color balance(Gain, Bias).

#### Copy From

- The Gain and Bias data of each Color Temp. are restored to User adjustment.

### Page 2/3

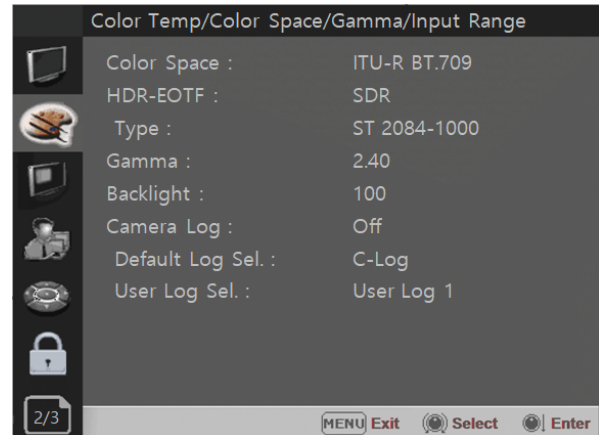

#### Color Space

Selects the color space from among [ITU-R BT.709], [SMPTE-C],[EBU], [DCI-P3], [ITU-R BT.2020], [Native],[ACES Proxy].

- The different setting value can be adjusted to each Screen.

#### HDR-EOTF

Selects the color space from among [SDR],[HDR], [ITU-R BT.1886].

#### Type

Selects 4 modes of HDR gamma.

- ST-2084 800 \* \* : This mode displays the absolute brightness up to 800cd/m<sup>2</sup>. So, the highlights over 800cd/m<sup>2</sup> are clipped.
- ST-2084 1000 : This mode displays the relative brightness up to 1000cd/m<sup>2</sup>. The part exceeding 1000cd/m<sup>2</sup> is clipped.
- ST-2084 10000 : The characteristics of LCD panel doesn't allow to produce the ideal brightness required by this standard, so the gamma is displayed in the relative brightness
- HLG-1.15(800) \* \* (Hybrid Log Gamma) : This mode can be selected when the White is 300 cd/m<sup>2</sup> in HLG..
- HLG-1.0 / 1.1 / 1.2 / 1.3 / 1.4 / 1.5 : These modes allow the user to apply HLG from 1.0 up to 1.5.
- HLG-SG(1.2): HLG gamma is applied to 1.2 and then displayed in the absolute value up to 300cd/m<sup>2</sup>.
- S-Log3: Select the S-Log3(HDR) gamma.
- ST-2084 4000 : This mode displays the relative brightness up to 4000cd/m<sup>2</sup>. The part exceeding 4000cd/m<sup>2</sup> is clipped.



## Color Temp/Color Space/Gamma Menu/Input Range Menu

- ToneMappingPQ-1,000/4,000/10,000:  
Tone mapping mode can be set to 1,000, 4,000, or 10,000.

### ST-2084 800 \*\*

As shown in the graph below, only the expression according to the maximum panel brightness level of the model is clipped.

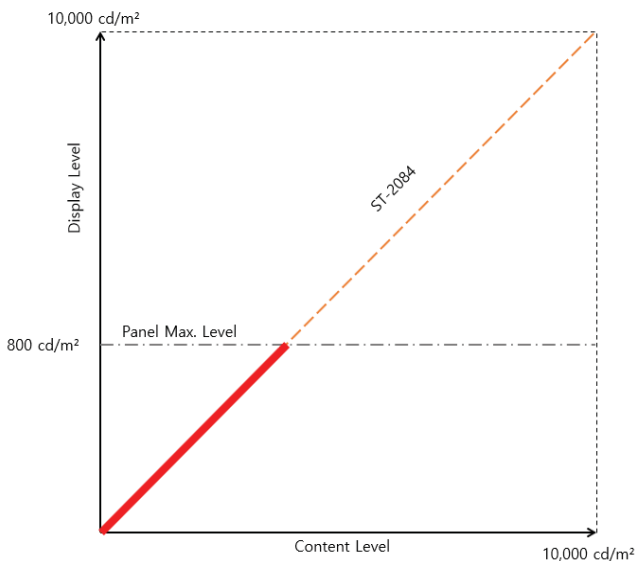

### ST-2084 1,000

As shown in the graph below, within the panel maximum brightness level 800 cd/m<sup>2</sup> section of the model, the data level is only expressed up to 1,000 cd/m<sup>2</sup> and then clipped

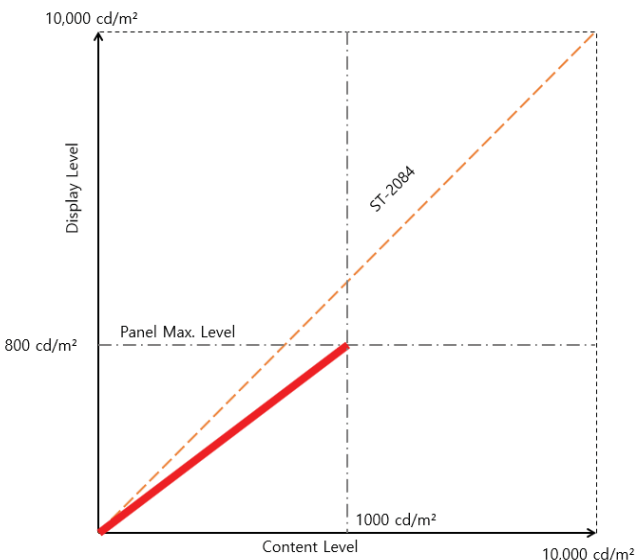

### ST-2084 10,000

As shown in the graph below, within the panel maximum brightness level 800 cd/m<sup>2</sup> section of the model, the data level is only expressed up to 10,000 cd/m<sup>2</sup> and then clipped.

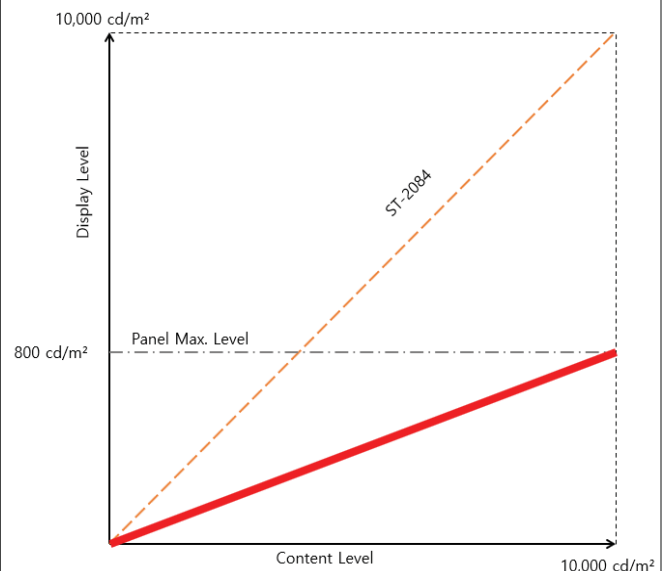

### Tonemapping PQ 1,000

As shown in the graph below, within the panel maximum brightness level 800 cd/m<sup>2</sup> section of the model, the data level is only expressed up to 1000 cd/m<sup>2</sup> and then clipped. And the section below is expressed according to the standard level.

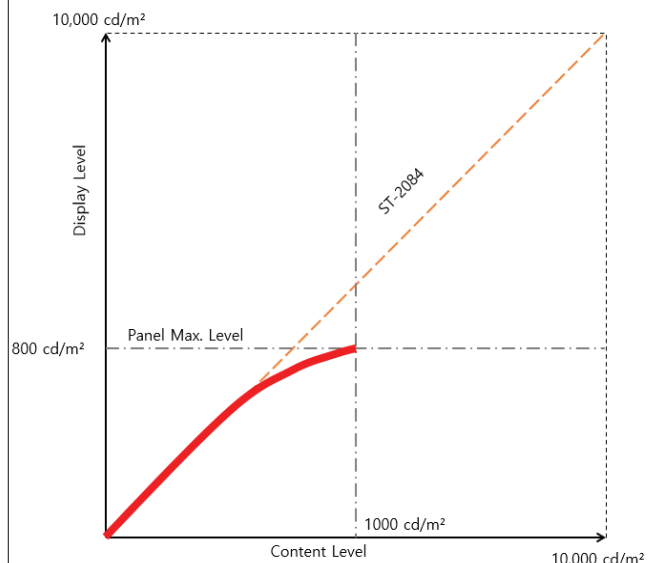





## Color Temp/Color Space/Gamma Menu/Input Range Menu

### Tonemapping PQ 4,000

As shown in the graph below, within the panel maximum 800 cd/m<sup>2</sup> section of the model, the data level is only expressed up to 4000 cd/m<sup>2</sup> and then clipped. And the section below is expressed according to the standard level.

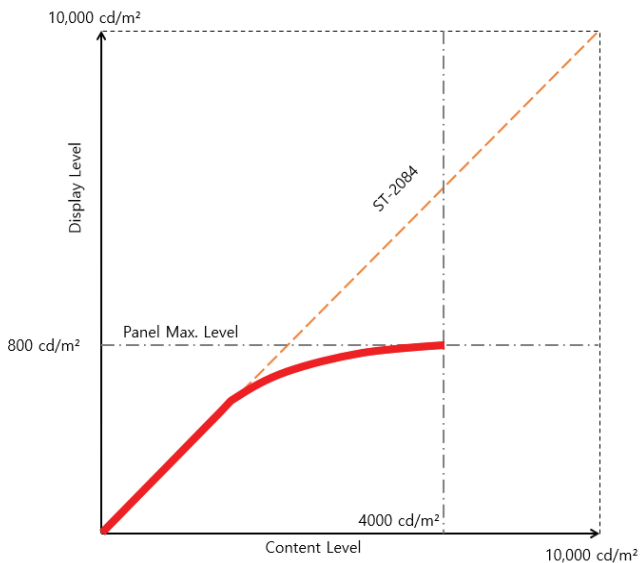

### Tonemapping PQ 10,000

As shown in the graph below, within the panel maximum 800 cd/m<sup>2</sup> section of the model, the data level is only expressed up to 10,000 cd/m<sup>2</sup> and then clipped. And the section below is expressed according to the standard level.

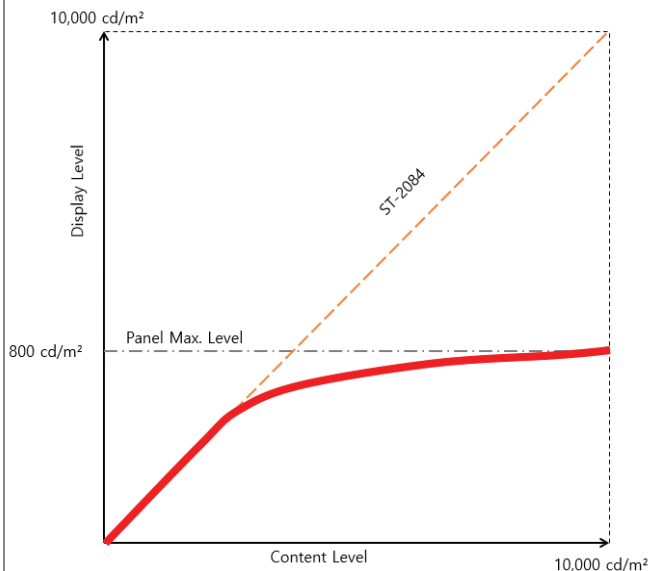



### Color Temp/Color Space/Gamma Menu/Input Range Menu

\*\* 1) OSD Menu of this mode is different, depending on each model's HDR maximum luminance.

#### HDR maximum luminance

OBM-U170Q : 1000 cd/m<sup>2</sup>  
 OBM-U240Q : 400 cd/m<sup>2</sup>  
 OBM-U310Q : 700 cd/m<sup>2</sup>  
 OBM-U420Q : 400 cd/m<sup>2</sup>

2) PQ and HLG gamma is different, depending on each model's luminance.

OBM-U170Q : ST 2084-1000- HLG-1.2(1000)  
 OBM-U240Q : ST 2084-400- HLG-1.03(400)  
 OBM-U310Q : ST 2084-700- HLG-1.13(700)  
 OBM-U420Q : ST 2084-400- HLG-1.03(400)

#### Gamma

Selects the appropriate gamma mode from 1.00 to 3.00.

- The different setting value can be adjusted to each Screen.

\*\*Note- When the HDR-EOTF is set [SDR], this menu becomes activated.- When the color space is set to [Native] or [ACES Proxy], this menu becomes deactivated.

-When the color space is set to Native, this menu becomes deactivated.

#### Back Light

Adjusts the level of the back light level. If the back light value is increased, the screen becomes brighter.

\*\* If the setting in Color Temp. menu and Color Space menu is changed, the value of Back Light returns to the default value of the color calibration in the factory.

#### Camera Log

Selects a camera log for the input signal.

[Off]: Sets off the camera log.

[Default]: The log which is selected in [Default Log Sel.] menu is applied.

[User]: The log which is selected in [User Log Sel.] menu is applied.

[Import Log Data]: Allows the user to save the Log LUT in USB memory stick to the monitor. The saved LUT can be used in User Log.

#### Default Log Sel

Allows the user to select a camera log among Log-C EI 160~3200, S-Log2 To LC-709, S-Log2 To LC-709TypeA, S-Log2 To Slog2-709, S-Log2 To Cine+709, S-Log2 To LC-709, S-Log3 To LC-709TypeA, S-Log3 To Slog2-709, S-Log3 To Cine+709, J-Log1.

#### User Log Sel

Selects User Log 1 to 4.

#### \*\*Note

- If you insert the USB memory stick which contains the user log data to the monitor and push Enter in [Import Log Data] menu, the data is saved to the monitor.

- The file name of the user log data is displayed on the OSD up to 15 characters, and the log data file should be placed on the top folder of the USB memory stick.

Ex) If the file name is 'S-log3 to LC709\_A.cube', it is displayed as 'S-log3 to LC709' on the OSD.



## Color Temp/Color Space/Gamma ...

Page 3/3

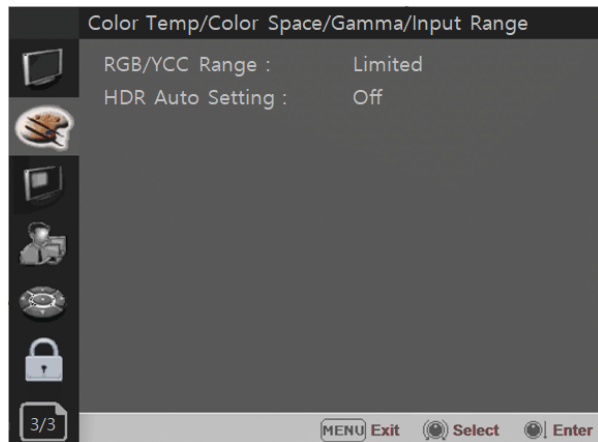

### RGB/YCC Range

- Selects Black Level and White Level of RGB/YCC format.
- The different setting value can be adjusted to each Screen.

### SDI :

Limited : 64(10bit)/256(12bit)~  
1023(10bit)/4095(12bit)  
Full : 4/16(Black Level) ~  
1023(10bit)/4095(12bit)

### HDMI :

Limited : 64(10bit)/256(12bit)~  
1023(10bit)/4095(12bit)  
Full : 0(Black Level) ~  
1023(10bit)/4095(12bit)

### HDR Auto Setting

This function allows the monitor to read the Transfer Characteristics and Colorimetry information of Payload identifiers of the ST2082-10 12G SDI signal and adjust HDR automatically.

- Transfer Characteristics : SDR, ST2084-1000, HLG1.2
- Colorimetry : Rec709, Rec 2020



## Camera Assist Menu

Page 1/2

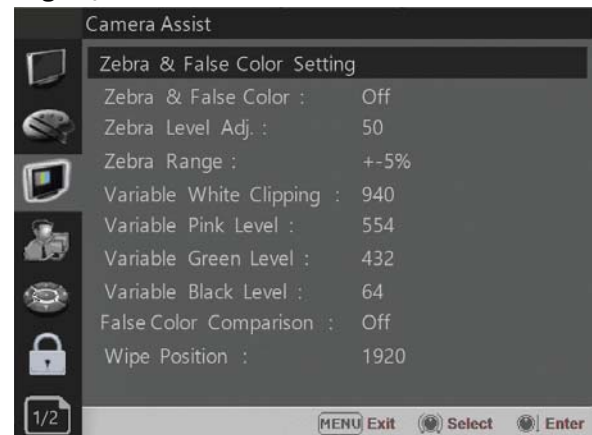

### Zebra & False Color

- Evaluates the Luma(Y') level of the input image. If the certain Y' level is set, the pixels with the designated Luma(Y') level are displayed in zebra pattern. ( *This feature only works in single mode or 4K mode.* )

#### Zebra

Pixels with Y' level over 100% turn to red zebra pattern, and pixels with Y' level under 0% turn to green zebra pattern.

#### Zebra Level Adjustment

- Adjusts the Y' level as the user wants.

#### Zebra Range

- Adjusts the Y' level as the user wants.

### False Color ARRI

The color pattern is displayed with ARRI camera

Color	Level	Description
red	99~100%	White clipping
yellow	97~99%	Just below white clipping/white shoulder
pink	52~56%	One stop over medium gray (Caucasian skin)
green	38~42%	18% neutral gray
blue	2.5~4.0%	Just above black clipping/black slope
purple	0~2.5%	Black clipping

### False Color Variable

This mode allows the user to adjust White clipping, Pink level, Green level, Black Clipping.

#### Variable White Clipping

- Adjusts White Clipping from 0 to 1023.

#### Variable Pink Level

- Adjusts Pink level from 0 to 1023.

#### Variable Green Level

- Adjusts Green level from 0 to 1023.

#### Variable Black Clipping

- Adjusts Black Clipping from 0 to 1023.



## Camera Assist Menu

Page 2/2



### Focus Assist

- Controls the aperture level of a video signal and displays images on screen with sharpened edges to help camera focus operation.  
(This feature only works in single mode or 4K mode.)

Available types are [Color On] and [Mono On].

- [Color On]: The background image is the original color type.
- [Mono On]: The background image is the mono type.

### Color

- Selects a color for Focus Assist among [RED], [Green], [Blue], [White], [Yellow], [Cyan].

### Frequency

- Adjusts the edge difference level between the edges in an image.
- Available values are from 0% to 100%.



## User Configuration Menu

User Configuration consists of the adjustment menus such as [User Preset Setting], [Function Button Setting], [Input Setting], [Output Setting], [Speaker Out / Audio Level Meter Setting], [Marker Setting], [WFM/Vector Setting], [Closed Caption Setting], [System Setting].

Page 1/7

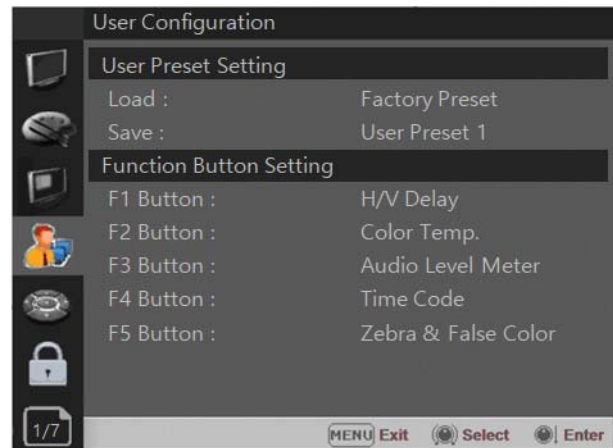

### User Preset Setting

- [Load] : Load the saved settings in [User Preset1], [User Preset2], [User Preset3], [User Preset4], [User Preset5] and [Factory Preset].
- [Save] : Save the current setting status to [User Preset1], [User Preset2], [User Preset3], [User Preset4], or [User Preset5].

\*\* When [User Preset Lock] of [Password] is set [On], [User Preset 1] setting values are protected by password. If you want to save the changed setting values to [User Preset 1], you can enter the password first to set [User Preset Lock] to [Off] and then save the values.

### Function Button Setting

- Assigns the function for F1 to F5 buttons on the front panel.
- The following functions can be assigned. :
- \*[HDMI to Screen4], [H/V Delay], [Color Temp.], [Audio Level Meter], [Time Code],[Zebra & False Color], [Focus Assist], [WFM/Vector], [Camera Log], [HDR-EOTF], [Freeze], [Black Stretch], [False Color Comparison], [Gamut Error], [Cam.log Mapped SDI-Out], [ITU-R BT.709],[ITU-R BT.2020],[DCI-P3] [ST-2084-1000], [ST-2084-4000], [Backlight], [User Preset 1], [User Preset 2], [User Preset 3], [User Preset 4], [User Preset 5], [Fixed Signal Format],[SFP-1 to Screen1],[SFP-2 Screen2]



## User Configuration Menu

- The following functions are assigned in the factory.
  - [F1]: HDMI to Screen 4(2) / (4:quad, 2:PBP)
  - [F2]: H/V Delay
  - [F3]: Color Temp
  - [F4]: Audio Level Meter
  - [F5]: Time Code

### Page 2/7

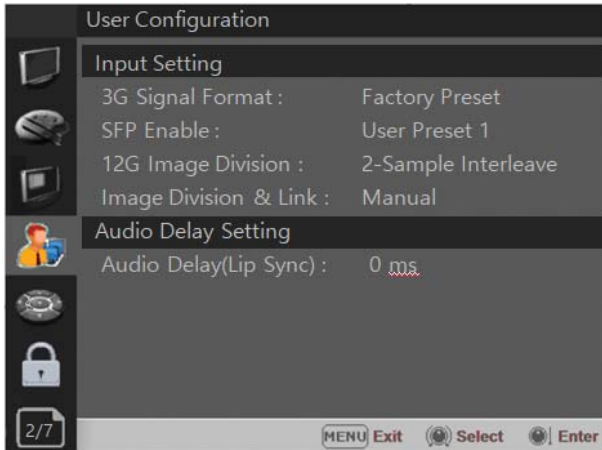

### Input Setting

#### 3G Signal Format

- Selects the format of 3G SDI input signal.
  - [Auto],[A 4:4:4 YUV 10b],[A 4:4:4 GBR 10b],
  - [A 4:4:4 YUV 12b],[A 4:4:4 GBR 12b],
  - [A 4:2:2 YUV 12b],[B DL 4:4:4 YUV 10/12b],
  - [B DL 4:4:4 GBR 10/12b],[B DL 4:2:2 YUV 12b],
  - [B DL 4:2:2 YUV 10b 60p]
- The different setting value can be adjusted to each Screen.

#### SFP Enable

- Allows for SFP input to be selected by pushing [SINGLE] button on the front panel.

#### 12G Image Division

- Selects the image division of the 12G-SDI Single Link signal between [2-Sample Interleave] and [Square]

\*\*Payload ID of 12G-SDI 2-Sample Interleave signal and 12G-SDI Square division signal is the same. So, Image Division cannot be detected automatically, and the user has to select it. The default setting is [2-Sample Interleave].

#### Image Division & Link Order

- Select from [Manual] or [Auto].

### [Auto]:

Square / 2-S.I. The input automatically recognizes the VPID (Video Payload ID) embedded in the SDI signal when it is normally present, and even if the input is not connected properly, it splits the image or links in order to reduce user error. Set automatically.

Also, when 12 signals are input, it automatically switches to single mode.

\* Quad-Link Square / 2-S.I in single mode.

In mode It does not change automatically.

### Audio delay setting

#### Audio delay (lip sync)

- Set the delay time between the video and audio signals. (0ms to 170ms). 17 steps.



## User Configuration Menu

### Page 3/7

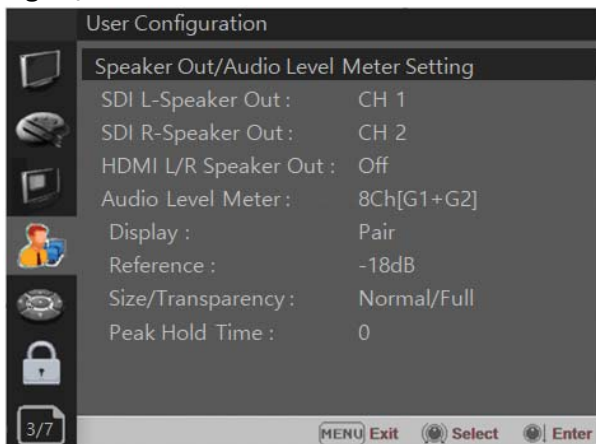

#### Speaker Out / Audio Level Meter Setting

- Selects the audio channel of the SDI & HDMI input signal.

#### SDI : Left Speaker Out / Right Speaker Out

- Selects the embedded audio channel for the left and right audio out of the Headphone jack on the front panel of the monitor.

Audio channel can be selected among Ch1 ~ Ch16, Analog.

#### HDMI : L/R Speaker Out

- Selects the embedded audio channel of the HDMI signal. The available modes are [Off], [HDMI On], [Analog On].

#### Audio Level Meter

Selects the embedded audio mode.  
: [Off], [8Ch [G1+G2]], [8Ch [G2+G3]], [8Ch [G3+G4]], [8Ch [G1+G3]], [8Ch [G1+G4]], [8Ch [G2+G4]], [16Ch [G1~G4]]

\*\* In HDMI input, either [Off] or [HDMI 2Ch] can be selected.

#### Display

Selects the display method for Audio Level Meter. Available modes are [Group] and [Pair].  
\*\* In HDMI input, the mode is fixed to [Pair].

#### Reference

Selects the default value of Audio Level Meter. Available options are [-18dB] and [-20dB].

#### Size/Transparency

Selects the size and transparency of Audio Level Meter.

Available options are [Normal/Full], [Normal/Half], [Large/Full], [Large/Half].

#### Peak Hold Time

Controls the speed rate of Peak Hold Decay Time occurring when the audio volume decreases.

### Page 4/7

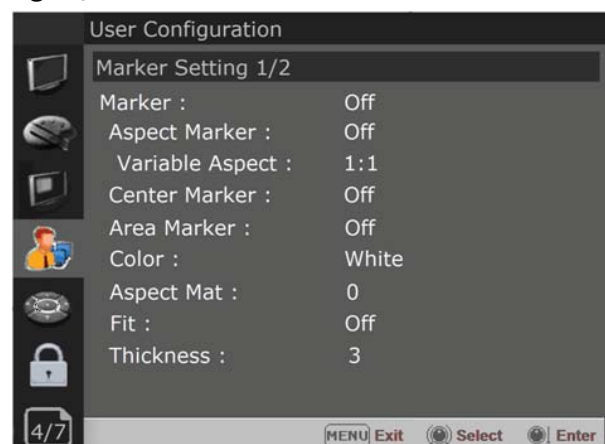

#### Marker Setting

##### Marker

- Selects On to display the marker, and Off to deactivate it.

- The different setting value can be adjusted to each Screen.

##### Aspect Marker

Selects the aspect ratio of the marker.

You can select from among [Off], [16:9], [4:3], [4:3 ON AIR], [15:9], [14:9], [13:9], [1.85:1], [2.35:1], [2.39:1], [1.85:1 & 4:3], [1.66:1], [1.896:1], [Variable], [Custom].

##### \*Variable Aspect

Allows the user to select the aspect ratio from the range between 1.00:1 and 3.00:1.

##### Center Marker

Selects On to display the center marker and Off not to display it.

##### Area Marker

Selects the size of the area marker.

You can select from among [Off], [80%], [85%], [88%], [90%], [93%], [100%], [EBU Action 16:9], [EBU Graphic 16:9], [EBU Action 14:9], [EBU Graphic 14:9], [EBU Action 4:3], [EBU Graphic 4:3].

##### Color

Selects the color of the marker.

You can select from among [White], [Gray], [Red], [Green], [Blue], [Yellow], [Cyan], [Magenta].

##### Aspect Mat

Darkens the outside of the area of the Aspect Marker. You can select from 0 to 7.

##### Fit

With Fit On, the Area Marker is displayed relative to the Aspect Marker in use.

With Fit Off, the Area Marker is displayed relative to the incoming video source.

##### Thickness

Adjusts the thickness of the marker lines. You can select it from 1 to 7.



## User Configuration Menu

### Page 5/7

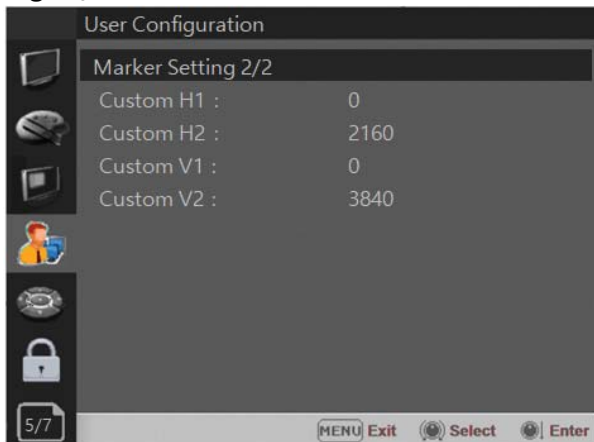

### Marker Setting 2/2

This function is activated when the “Aspect Marker” is set [Custom].

Menu > User Configuration 4/8 > Marker > Aspect Marker > Custom

#### Custom H1

- Sets the position of the first horizontal marker line.

#### Custom H2

- Sets the position of the second horizontal marker line.

#### Custom V1

- Sets the position of the first vertical marker line.

#### Custom V2

- Sets the position of the second vertical marker line.

### Page 6/7



### WFM/Vector Setting

#### WFM/Vector

- Select [On] to display the [WFM/Vector] and [Off] not to display.

#### Type

- You can select from among [WFM], [VectorScope], [WFM+Vector]
- Single/PBP mode : [WFM]->[VectorScope]->[WFM+Vector]
- Quad : [WFM]->[VectorScope]

\*This function doesn't work when RGB format signal is input.

#### Intensity

Adjusts the brightness of Waveform and Vectorscope display.  
You can select from 1 to 64.

#### Transparency

Adjusts the transparency level of Waveform and Vectorscope.

[Black]: The background is black. Displayed image is hidden behind the background.

[Half]: The background is transparent. Displayed image can be seen indistinctly behind the Waveform and Vectorscope display.

#### Color

Selects the color of Waveform monitor.  
Available colors are [Green] and [White].

#### Position

- Sets the display position of the [WFM/Vector].  
Select [Right Bottom], [Left Bottom],[Left Top], or [Right Top].



## User Configuration Menu

Page 7/7

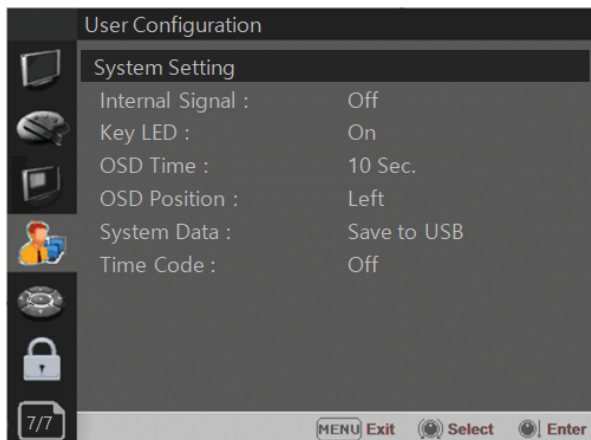

### System Setting

#### Internal Signal

Generates the White Pattern internally. The selectable range is from 100%(White) to 0%(Black), ColorBar.

#### Key LED

Sets On to turn on the LED of the keys, and sets Off to turn off the LED of the keys.

#### OSD Time

- Adjusts the display time of the OSD menu.
- [10 Sec.]: The OSD menu will be disappeared after 10 seconds.
- [20 Sec.]: The OSD menu will be disappeared about 20 seconds.
- [30 Sec.]: The OSD menu will be disappeared about 30 seconds.
- [On]: The OSD menu will not be disappeared.

#### OSD Position

Sets the position of OSD. Selects [Left] or [Left Top].

#### System Data

- [Save to USB]  
Saves the current settings of the monitor to the USB memory.
- [Copy from USB]  
Recalls the settings saved in the USB memory, and load them to the monitor. (User preset settings are also saved as values loaded from USB memory.)
- The R/G/B gain obtained by color calibration is not saved in USB memory or loaded to the monitor.
- If User Preset Lock is turned on in Security, User Preset 1 among the set values retrieved from USB memory is not saved in the monitor and retains the existing values.

#### Time Code

- Selects the type of the time code to be displayed.
- [VITC]: To display the VITC time code
- [LTC]: To display the LTC time code



## Remote Menu

Page 1/3

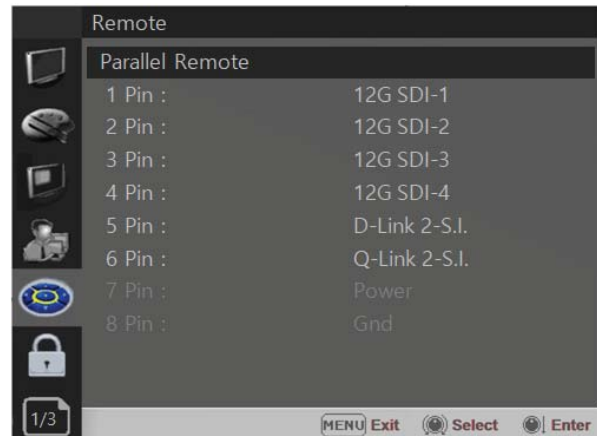

### Parallel Remote

Selects the Parallel Remote connector pins for which you want to change the function. Various functions can be assigned to pin 1 to 6. The following is the lists of the functions which can be assigned to the pins.

[--]	[Blue Only]
[12G SDI-1]	[Blue Only Mono]
[12G SDI-2]	[Marker]
[12G SDI-3]	[Tally R]
[12G SDI-4]	[Tally G]
[D-Link 2-S.I.]	[User Preset 1]
[Q-Link 2-S.I.]	[User Preset 2]
[D-Link SFP]	[User Preset 3]
[Square SDI]	[User Preset 4]
[Quad SDI]	[User Preset 5]
[PBP DSI]	[ITU-R BT.709]
[HDMI]	[ITU-R BT.2020]
[SFP-1]	[HDR-EOTF]
[SFP-2]	[Cam.Log Default]
[Zero Scan]	[Cam.Log User]
[1:1 Scan]	[Channel1 Tally]
[4:3 Aspect]	[Channel2 Tally]
[16:9 Aspect]	[Channel3 Tally]
[Auto Aspect]	[Channel4 Tally]
[H/V Delay]	

- \*\* [--]: No function is assigned
- \*\*7 Pin: For Power On and Off only
- \*\*8 Pin: For Ground only





## Remote Menu

### Page 2/3



#### Monitor ID

Sets the ID of the monitor to control the monitor through Serial Remote or Network.

#### In-Monitor Display Setting

The monitor supports "TSL UMD Protocol – V3.1 & V5.0" provided by Television System Ltd. [Transparency], [Text Color], [Left Tally Color], [Right Tally Color] can be set in the setting menu.

\*\* The monitor displays English alphabet, numbers, Symbolic codes.

\*\* Up to 16 characters can be displayed in English.

#### IMD Type

- Selects the In-Monitor Display type.

Available modes are [Off],[TSL V3.1],[TSL V5.0],[User].

#### User Text

-If the IMD type is User, the user can set the ASCII character table up to 8 characters arbitrarily.

#### Transparency

- Selects [Full] or [Half] for the background of IMD.

-[Full]: The background is black. Displayed image is hidden behind the background.

-[Half]: The background is transparent. Displayed image can be seen indistinctly behind the IMD display.

#### Text Color

- Selects the color of text displayed in IMD.

- The user can select from among [White], [Gray], [Red], [Green], [Blue], [Yellow], [Cyan], [Magenta].

#### L-Tally Color

- Selects the color of left tally lamp displayed in IMD.
- The user can select from among [White], [Gray], [Red], [Green], [Blue], [Yellow], [Cyan], [Magenta].

#### R-Tally Color

- Selects the color of right tally lamp displayed in IMD.
- The user can select from among [White], [Gray], [Red], [Green], [Blue], [Yellow], [Cyan], [Magenta].

### Page 3/3

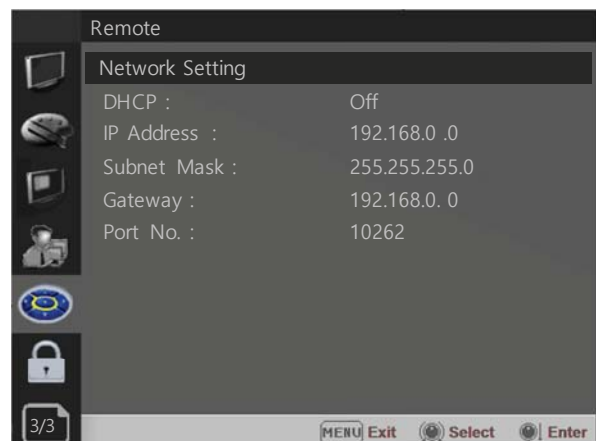

#### Network Setting

##### DHCP

- Toggle DHCP On or Off.

DHCP allows your monitor to receive an IP address from your network for remote control via various programs.

##### IP Address, Subnet Mask & Gateway

- The user can manually configure network settings when DHCP is disabled.

##### Port No.

- Sets the port number.



## Remote Menu

### \*\*Note

SFP module support is activated only when the module is first connected and the monitor power is turned on.

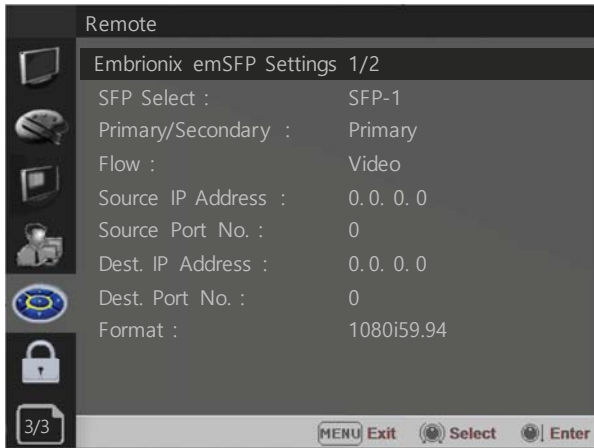

### Embrionix emSFP Setting 1/2

#### SFP Select

- Select the optical module to be used. (SFP-1, SFP-2)

#### Primary/Secondary

- Select the page of emSFP flow. (Primary/Secondary)

#### Flow

- Select emSFP flow. (Video/Audio1/Audio2/Audio3/Audio4/Ancillary)

#### Source IP Address/Port No.

- Set Source IP/Port.

#### Dest. IP Address/Port No.

- Set the destination IP/Port.

#### Format

- Set the video signal format. (720p50,720p59.94,720p60,720p23.98,720p24,720p25,720p29.97,720p30,1080p23.98,1080p24,1080p25,1080psf25,1080psf29.97,1080psf30,1080p30,1080psf30,1080i50,1080i59.94,1080i60,3GA 1080p50,3GA 1080p59.94,3GA 1080p60,2048x1080p23.98,2048x1080p24,2048x1080p25,2048x1080p29.97,2048x1080p30,3GA 2048x1080p48,3GA 2048x1080p50,3GA 2048x108p59.94, 3GA 2048x1080p60)

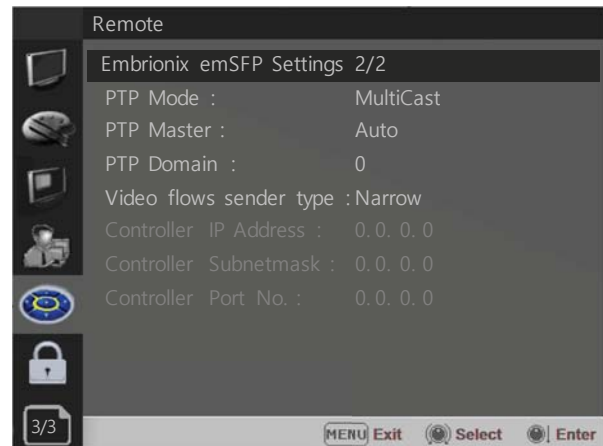

### Embrionix emSFP Setting 2/2

#### PTP Mode

- Set the Precision time protocol (PTP) mode. (Multicast, Hybrid, Unicast)

#### PTP Master

- Set the UUID (Universally Unique Identifier) mode. (Auto, Manual)

#### PTP Domain

- Set the domain number of the PTP Master. (0-255)

#### Video flows sender type

- Set the sender type of the emSFP video flow. (Narrow, Narrow linear, Wide)

#### Controller IP Address, Subnetmak, Port No.

- Shows emSFP's control IP/Subnetmask and Port No.



## Security Menu

Page 1/1

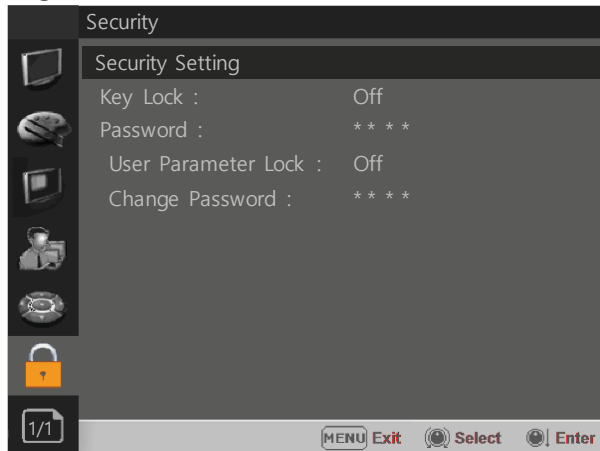

### Security Setting

#### Key Lock

When Key Lock function is set On, the change of the menu settings and functions doesn't work.

\*\* The same function as [Key Lock] button on the front panel.

#### Password

- This function allows the user to protect the setting values through password.
- When the Password lock is applied, the functions and the setting values can be changed, but they are not saved.
- When you protect the setting values with a password, set a four-digit number.
- The initial password is 0000.
- When you use [Password], change the initial password first.

#### User Parameter Lock

Selects [On] to protect the setting values.  
Selects [Off] to not protect by the password.  
When [On] is selected, OSD background is displayed with the lock image as shown below.

#### Change Password

Changes the password.

## 7. Scan Mode Image

### 4K/QFHD Mode

The LCD panel resolution of OBM-U170Q/U240Q/U310Q/U420Q is QFHD(16:9) 3840x2160, so if the input signal is 3840x2160 1:1 mapping is supported. If the input signal is DCI 4K(4096x2160), 1:1 mapping is not supported.

#### [Zero Scan]

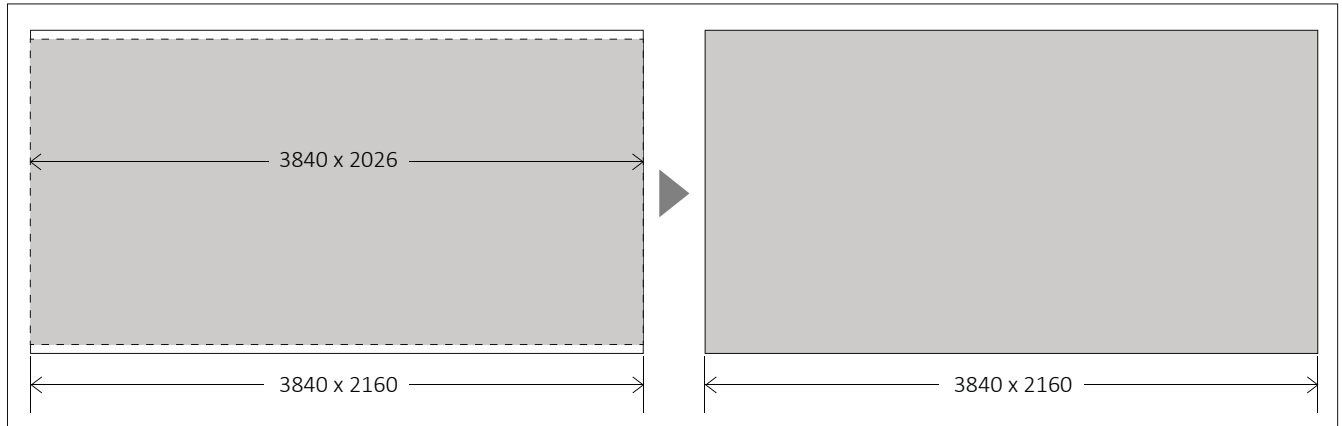

When the 4096x2160 signal is fed, if you select Zero Scan using [Scan] button on the front panel, the picture is scaled to be displayed on the panel of 3840x2026 resolution with maintaining 1.89:1 ratio.

#### [1:1 Scan]

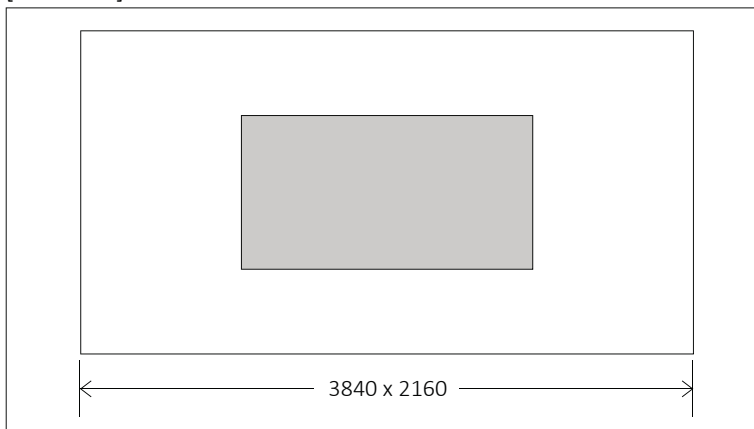

When 1:1 Scan mode is selected with the [Scan] button in 1920x1080, 1280x720 mode, etc., it is placed in the center of the screen as above. A 1:1 mapped image is output.

## 8. Connecting the SDI Signals

Single Link 12G/6G/3G/HD-SDI, Dual-Link 6G/3G-SDI, Quad Link 12G/6G/3G/-SDI signals can be Input to the SDI In connectors of this monitor.

Up to 4-channel Single Link 12G/6G/3G/HD-SDI signals, 1-channel Dual-Link 6G/3G-SDI or 1-channel Quad-Link 12G/6G/3G-SDI signals can be input. Use the appropriate input connectors depending on the input signal, referring to the table below.

### Single-Link Signal

Connector	Input signal
12G SDI-1	12G/6G/3G/HD
12G SDI-2	12G/6G/3G/HD
12G SDI-3	12G/6G/3G/HD
12G SDI-4	12G/6G/3G/HD

### Dual-Link 3G –SDI Signal

\* 2-sample interleave division signals

Connector	Input signal
12G SDI-1	6G/3G SDI Link1
12G SDI-2	6G/3G SDI Link2

### Quad-Link Signal

\* 2-sample interleave division signals

Connector	Input signal
12G SDI-1	12G/3G Link1
12G SDI-2	12G/3G Link2
12G SDI-3	12G/3G Link3
12G SDI-4	12G/3G Link4

### Quad-Link Square Signal

Connector	Input signal
12G SDI-1	12G/3G/HD Link1
12G SDI-2	12G/3G/HD Link2
12G SDI-3	12G/3G/HD Link3
12G SDI-4	12G/3G/HD Link4

### Quad Signal

Connector	Input signal
12G SDI-1	12G/6G/3G/HD
12G SDI-2	12G/6G/3G/HD
12G SDI-3	12G/6G/3G/HD
12G SDI-4	12G/6G/3G/HD

### PBP Signal

Connector	Input signal
12G SDI-1	6G/3G SDI Link1
12G SDI-2	6G/3G SDI Link2

### Image of Square division signals

Sub-Image1 (upper-left screen)	Sub-Image2 (upper-right screen)
Sub-Image3 (lower-left screen)	Sub-Image4 (lower-right screen)

\* Only progressive signals are supported in Dual-Link and Quad-Link modes.

## 9. Available Signal Formats

This monitor is applicable to the following signal formats

### Single / Quad / PBP HD-SDI

Signal System	Signal Format
1920 x 1080 / 23.98, 24, 25, 29.97, 30p/Psf, 50, 59.94, 60i	4:2:2 YCbCr 10bit
2048 x 1080 / 23.98, 24, 25, 29.97, 30p/Psf	4:2:2 YCbCr 10bit
1280 x 720 / 23.98, 24, 25, 29.97, 30, 50, 59.94, 60p	4:2:2 YCbCr 10bit

### Single / Quad / PBP HD-SDI

Signal System	Signal Format	
1920 x 1080 / 47.95, 48, 50, 59.94, 60p	4:2:2 YCbCr 10bit	Level A / Level B-DL
1920 x 1080 / 23.98, 24, 25, 29.97, 30p/Psf, 50, 59.94, 60i	4:4:4 RGB 10bit 4:4:4 YCbCr 10bit 4:4:4 RGB 12bit 4:4:4 YCbCr 12bit	Level A / Level B-DL
2048 x 1080 / 47.95, 48, 50, 60p	4:2:2 YCbCr 10bit	Level A / Level B-DL
2048 x 1080 / 23.98, 24, 25, 29.97, 30p/Psf	4:4:4 RGB 10bit 4:4:4 YCbCr 10bit 4:4:4 RGB 12bit 4:4:4 YCbCr 12bit	Level A / Level B-DL
1280 x 720 / 23.98, 24, 25, 29.97, 30, 50, 59.94, 60p	4:4:4 RGB 10bit 4:4:4 YCbCr 10bit	Level A

### Single / Quad / PBP 6G-SDI

Signal System	Signal Format
3840 x 2160 / 23.98, 24, 25, 29.97, 30p	4:2:2 YCbCr 10bit
4096 x 2160 / 23.98, 24, 25, 29.97, 30p	4:2:2 YCbCr 10bit

### SSingle / Quad / PBP 12G-SDI

Signal System	Signal Format
3840 x 2160 / 23.98, 24, 25, 29.97, 30, 47.95, 48, 50, 59.94, 60p	4:2:2 YCbCr 10bit
4096 x 2160 / 23.98, 24, 25, 29.97, 30, 47.95, 48, 50, 59.94, 60p	4:2:2 YCbCr 10bit

### Dual-Link (4K) 3G-SDI

Signal System	Signal Format	
3840 x 2160 / 23.98, 24, 25, 29.97, 30p	4:2:2 YCbCr 10bit	Level B-DS 2-sample interleave division
4096 x 2160 / 23.98, 24, 25, 29.97, 30p	4:2:2 YCbCr 10bit	Level B-DS 2-sample interleave division

### Dual-Link (4K) 6G-SDI

Signal System	Signal Format	
3840 x 2160 / 50, 59.94, 60p	4:2:2 YCbCr 10bit	2-sample interleave division
4096 x 2160 / 50, 59.94, 60p	4:2:2 YCbCr 10bit	2-sample interleave division

## Quad-Link (4K) HD-SDI

Signal System	Signal Format	
3840 x2160 / 23.98, 24, 25, 29.97, 30p	4:2:2 YCbCr 10bit	2-sample interleave division/ Square division
4096 x2160 / 23.98, 24, 25, 29.97, 30p	4:2:2 YCbCr 10bit	2-sample interleave division/ Square division

## Quad-Link (4K) 3G-SDI

Signal System	Signal Format		
3840 x2160 / 50, 59.94, 60p	4:2:2 YCbCr 10bit	Level A / Level B-DL	2-sample interleave division/ Square division
3840 x2160 / 23.98, 24, 25, 29.97, 30p	4:4:4 RGB 10bit 4:4:4 YCbCr 10bit 4:4:4 RGB 12bit 4:4:4 YCbCr 12bit	Level A / Level B-DL	
4096 x 2160 / 47.95, 48, 50, 59.94, 60p	4:2:2 YCbCr 10bit	Level A / Level B-DL	2-sample interleave division/ Square division
4096 x 2160 / 23.98, 24, 25, 29.97, 30p	4:4:4 RGB 10bit 4:4:4 YCbCr 10bit 4:4:4 RGB 12bit 4:4:4 YCbCr 12bit	Level A / Level B-DL	

## HDMI

Signal System	Signal Format
640 x 480p@59.94 / 60	4:4:4 RGB 8 / 10 / 12bit 4:4:4 YCbCr 8 / 10 / 12bit 4:2:2 YCbCr 12bit
720 x 480p@59.94 / 60	
720 x 576p@50	
1280 x 720p@50 / 59.94 / 60	
1920 x 1080i@50 / 59.94 / 60	
1920 x 1080p@23.98 / 24 / 25 / 29.97 / 30 / 50 / 59.94 / 60	
2048 x 1080p@23.98 / 24 / 25 / 29.97 / 30 / 47.95 / 48 / 50 / 59.94 / 60	
3840 x 2160p@23.98 / 24 / 25 / 29.97 / 30 / 50* / 59.94* / 60*	4:4:4 RGB 8bit 4:4:4 YCbCr 8bit 4:2:2 YCbCr 12bit *Supports 4:4:4 RGB 8bit only
4096 x 2160p@23.98 / 24 / 25 / 29.97 / 30 / 50* / 59.94* / 60*	
800 x 600p@60	4:4:4 RGB 8 / 10 / 12bit 4:4:4 YCbCr 8 / 10 / 12bit 4:2:2 YCbCr 12bit
1024 x 768p@60	

## 10. Key Functions

### Versatile 4K/QFHD Input Capability

The OBM-U\*\*\*Q series is equipped with standard 12G-SDI input interface(x4) and support 4K/8K Quad Link 2-sample interleave signals and 4K Quad Link Square Division signals.

The OBM-U\*\*\*Q Series can accept up to 7680x4320/23.98,24,25,29.97,30,50,59.94,60p and 8192x4320/23.98,24,25,29.97,30,50,59.94,60p



### 4K Waveform Monitor and Vector Scope Display

These features enable users to monitor sources using the internal Waveform and Vector Scope. Waveform Wide mode is supported, and both Waveform and Vector Scope can be displayed simultaneously.



### High Dynamic Range(HDR) Display Function

The OBM U\*\*\*Q series provides the function to display the High Dynamic Range footage. Postium HDR function allows users to view both highlights and shadow detail of scenes at the same time, thus resulting in more natural and realistic images.

The OBM U\*\*\*Q series supports PQ EOTF (SMPTE ST 2084), Hybrid Log Gamma and S-Log3.

HDR Mode

SDR Mode



OBM-HDR provides the function of comparing HDR and SDR(Standard Dynamic Range) on the displayed image on the OBM series simultaneously.



### Wide Color Space Supporting DCI-P3 and ITU-R BT.2020

The wide color gamut and the advanced 3D LUT function enable the OBM U\*\*\*Q series to reproduce various color spaces accurately and the excellent grayscale. You can select from color gamuts such as DCI-P3, ITU-R BT.2020, ITU-R BT.709, SMPTE-C, EBU, Native.

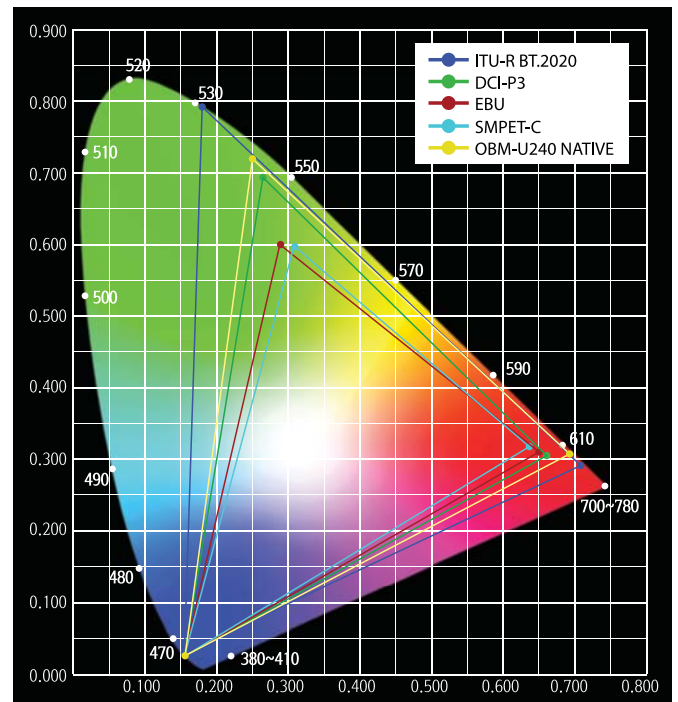



### Adjustable Gamma

Gamma value is adjustable from 1.0 to 3.0 as user's preference to monitor in the dark area of the picture. Any pictures taken in either light or dark environment can be easily watched or analyzed.



Gamma 1.8

Gamma 2.4

### Remote Control via Ethernet

The OBM U\*\*\*Q series can be connected via Ethernet connection and controlled remotely on the network.



### Focus Assist

This function controls the aperture level of a video signal, and displays images on screen with sharpened edges to help camera focus operation.



### Camera Log Selection

The OBM-U\*\*\*Q series have the built-in camera LUT of the various camera manufacturers. It allows users to load the following camera logs. Log-C, C-Log / S-Log2, S-Log3 / J-Log1  
The more camera LUTs will be updated.

### SFP Optical Connector

The OBM U\*\*\*Q series has the SFP interface, which allows to use the various SFP modules which can fit any possible broadcast applications.

### Custom 3D LUT File Import

The OBM-U\*\*\*Q Series allow the user to import 3D Look-up Table for accurate and consistent color matching between individual displays as well as using customized 'looks' that have been created by 3rd party color-grading applications. 32<sup>^3</sup>, 33<sup>^3</sup>, 64<sup>^3</sup> and 65<sup>^3</sup> cube file is supported.



## Various 4K/12G Display Modes Single Link 12G-SDI

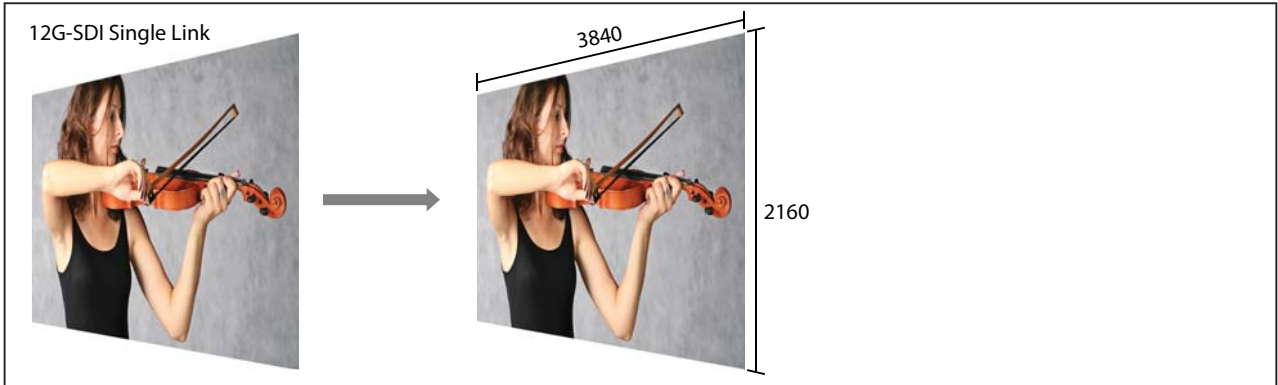

## Dual Link 2-Sample Interleave(2-SI)

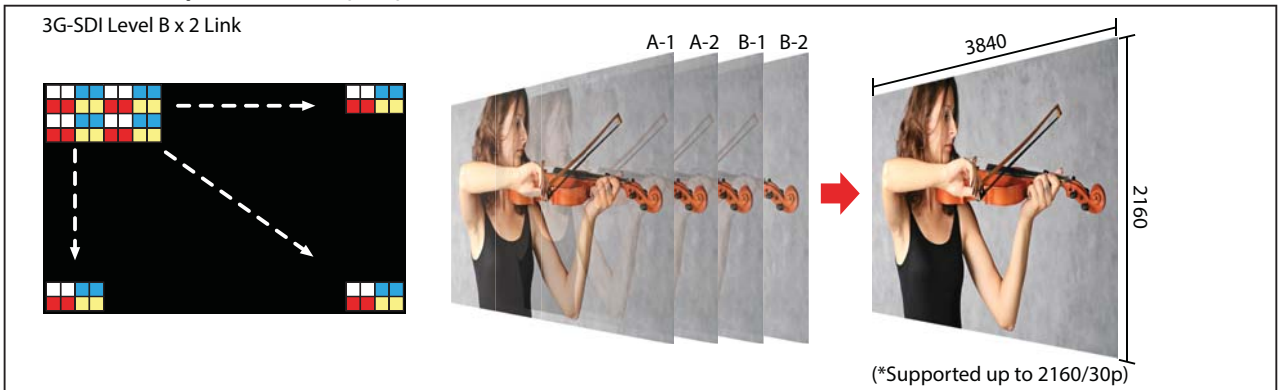

## Quad Link 2 Sample Interleave (2SI)

Each link contains a full image at 1/4 resolution. 2SI mode uses four Sub-image and alternates the samples every two pixels and every line instead of slitting the image into four quadrants.

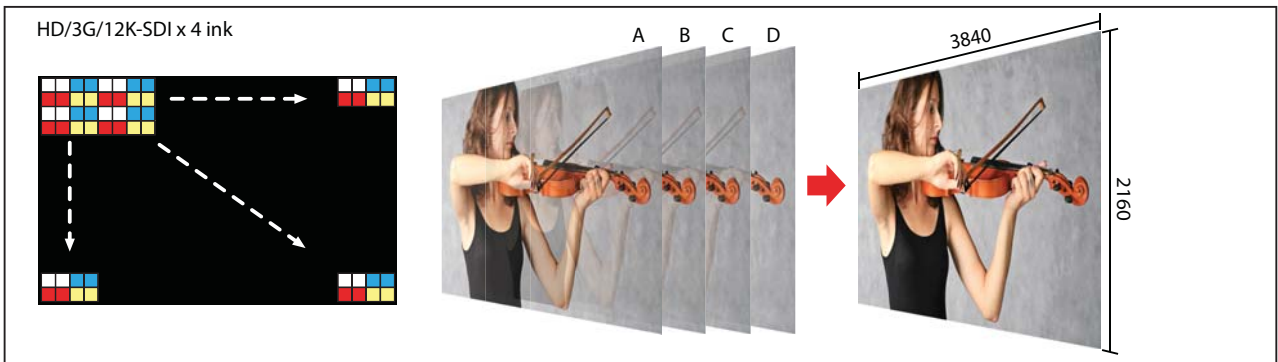

## Quad Link Square Division

Each link contains one square of the original image.

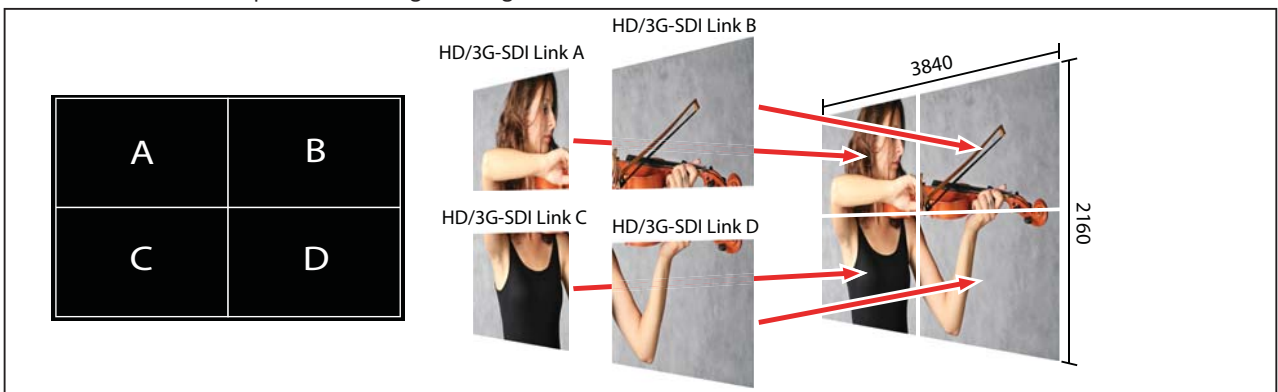

## False Color

This function evaluates the Luma(Y') level of the input image. If the certain Y' level is set, the pixels with the designated Luma(Y') level are displayed with the zebra pattern or the color pattern. There are three modes in OBM False Color.

### Zebra

This mode displays the Luma(Y') level of the input image in zebra pattern.



### False Color ARRI

The color pattern is displayed with ARRI camera standard.



### False Color Variable

This mode allows the user to adjust White clipping, Pink level, Green level, Black Clipping.



### False Color Comparison

This function enables the user to divide the picture side by side, and compare the original image on the left half and the False Color image on the right half.



### Supports 12G-SDI Single Link Square Division signal format

The OBM-U\*\*\*Qseries can display 12G-SDI Single Link 4K/UHD signals as well as 3G-SDI Quad Link signals. This is already a very useful feature, compared to competitors' monitors. Most of the single link 12G-SDI signals are displayed as 2-S.I. format on the screen. But, the single link 12G-SDI signals with Square Division format are increasing. In order to meet this requirement in the location and studio, the OBM-U\*\*\*8K series support both 12G-SDI Single Link 2-S.I. mode and 12G-SDI Single Link Square Division mode.

Single Link  
12G-SDI x 1



12G-SDI Single Link 2-Sample Interleave(2-S.I.) Mode



2-Sample Interleave(2-S.I.)

12G-SDI Single Link Square Division Mode



Square Division

### Meets the Return Loss Standard, SMPTE ST 2082-1:2015

In the professional broadcasting video industry, Return Loss is an important parameter that measures the reflected signal that bounces back from a terminated device. If the broadcast monitor has the poor return loss, the level of reflected signal negatively impacts the signal integrity of the loop-out signal. The OBM-U\*\*\*Q monitors meets the requirements of Return Loss specified in SMPTE ST 2081-1:2015, so that the OBM-U\*\*\*Qmonitors provides the high signal fidelity.

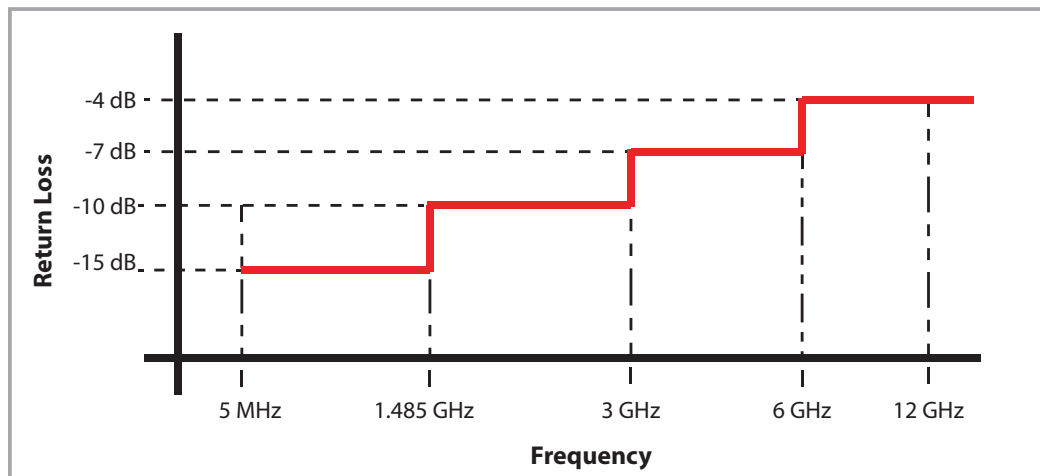

<SMPTE ST 2082-1:2015 Requirements>

### HDR Waveform

When HDR mode is set on, HDR Waveform is displayed on screen.

HDR Mode + HDR Waveform



HDR Waveform

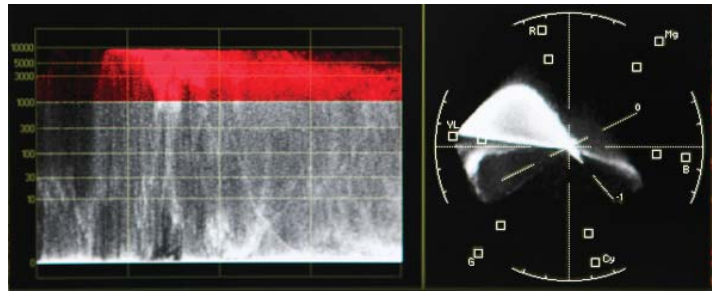

SDR Mode + SDR Waveform



SDR Waveform

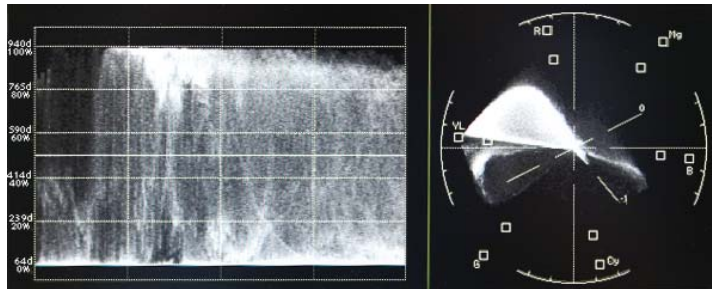

### In-Monitor Display(IMD) Function

The image source names and tally information can be displayed on the screen, with an external remote function via Ethernet. The TSL system protocol is supported. The color of the source name and tally color can be selectable among White, Red, Green, Blue, Yellow, Cyan, Magenta.



### Custom 3D LUT File Import

The OBM series allow the user to import 3D Look-up Table for accurate and consistent color matching between individual displays. as well as using customized 'looks' that have been created by 3rd party color-grading applications. 32<sup>^</sup>3, 33<sup>^</sup>3, 64<sup>^</sup>3 and 65<sup>^</sup>3 cube file is supported.



### Various Markers

The OBM U/X series can display various markers, including aspect marker, area marker, and center marker. In addition, the detailed display settings of each marker are allowed. For example, the color, brightness, horizontal/vertical position, and thickness of aspect markers can all be adjusted.



Display various markers

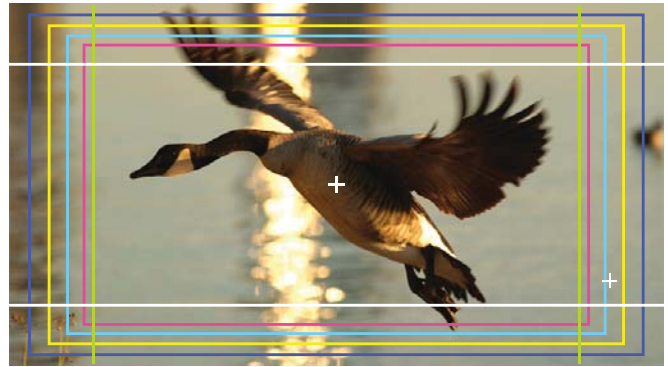

Display Color markers

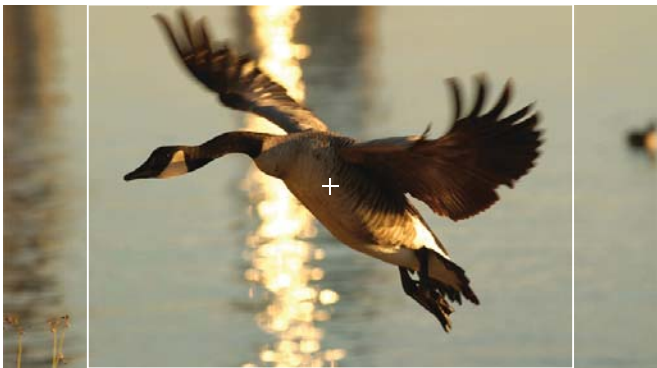

Aspect Mat 0

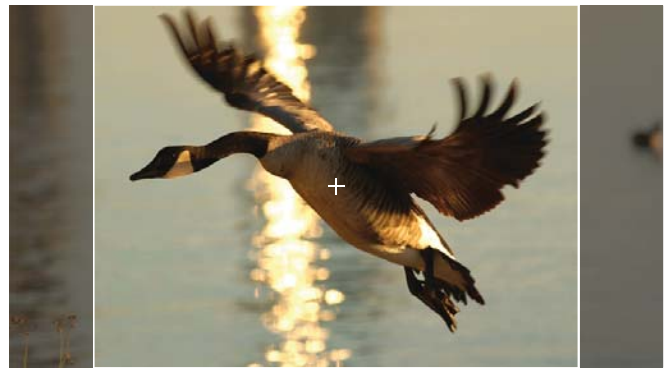

Aspect Mat 2

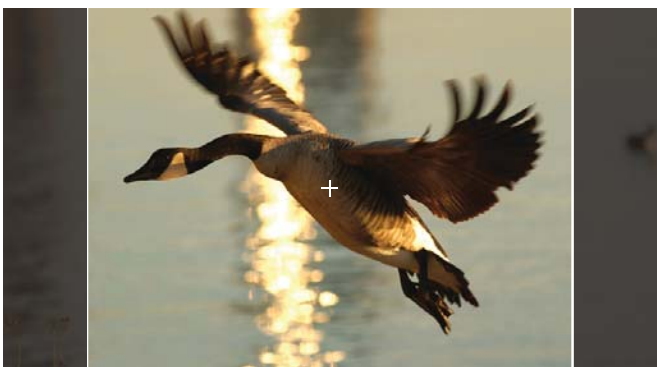

Aspect Mat 5

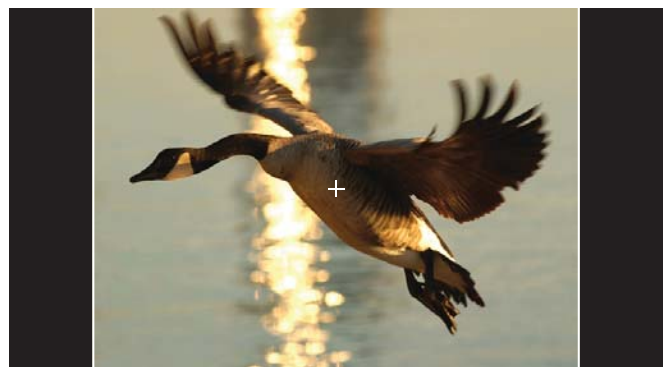

Aspect Mat 7

# 11. Product Specifications

## Specifications (OBM-U170Q)

ITEM		OBM-U170Q
Input	4 x BNC	12G/6G/3G/HD
	1 x HDMI	HDMI 2.0
	2 x SFP	SFP
Output	4 x BNC	12G/6G/3G/HD/4 Active Loop Output
Input Signal Format	SMPTE ST 2082-12(12G Quad 8K)	4320p(60/59.94/50)
	SMPTE ST 2082-10(12G Single)	2160p(60/59.94/50/30/29.97/25/24/23.98)
	SMPTE ST 2081-11(6G Dual)	2160p(60/59.94/50)
	SMPTE ST 2081-10(6G Single)	2160p(30/29.97/25/24/23.98)
	SMPTE ST 425-AB	1080p(60/59.94/50/30/29.97/25/24/23.98/30sF/29.97sF /25sF/24sF/23.98sF) / 1080i (60/59.94/50)
	SMPTE ST 274	1080p(30/29.97/25/24/23.98/24sF/23.98sF)
		1080i (60/59.94/50)
	SMPTE ST 296	720p(60/59.94/50)
	SMPTE ST 260	1920 x 1035i(60/59.94)
	SMPTE ST 2048	2048 x 1080p(24/23.98/24sF/23.98sF)
	HDMI 2.0	~ 2160p(60)
SFP	12Gbps, 6Gbps, 2.970Gbps, 1.485Gbps, 270Mbps	
Audio In/Out	1 x Phone Jack In	Line In(Stereo)
	1 x Phone Jack Out	H/P Out(Front, Stereo)
	2 x Speaker Out	Stereo
Display	Size	17.3" LCD
	Resolution	3840 x 2160 (16:9)
	Pixel Pitch	0.09945mm
	Color	1.064B Colors(8bit+Hi FRC)
	Viewing Angle	178(H), 178(V)
	Luminance of White	1500cd/m <sup>2</sup> (HDR Maximum 1000cd/m <sup>2</sup> )
	Contrast	1000 : 1
	Display Area (H x V)	381.89 x 214.81 (mm)
General	2 x Ethernet	Control/Update, RJ-45P Input / Output
	1 x GPIO	GPI-7 Port, RJ-45P Jack
	2 x Serial	RS-422 Jack, RJ-45P Input / Output
	1 x USB	For Firmware Update, Color Calibration
	Power Requirements	AC(100-230V, 50/60Hz)/DC 24V
	Power Consumption	75W
	Operating Temperature	0°C ~ 40°C(32°F~104°F)
	Operating Humidity	20% ~ 80% RH
	Weight	Main Body : 6.6kg / 14.55lbs (With Stand : 7.7kg / 16.97lbs)
	Dimensions (WxHxD)	Main Body : 436 x 310 x 81 mm(With Stand : 445 x 329 x 120mm)
		Main Body : 17.16 x 12.20 x 3.18inch (With Stand : 17.51 x 12.20 x 4.72 inch)
	Accessories	Power Cable
	Option	Rack Mount Kit/ Carrying Case

\* Specifications are subject to change without prior notice for the product quality improvement.

## Specifications (OBM-U240Q)

ITEM		OBM-U240Q
Input	4 x BNC	12G/6G/3G/HD
	1 x HDMI	HDMI 2.0
	2 x SFP	SFP
Output	4 x BNC	12G/6G/3G/HD/4 Active Loop Output
Input Signal Format	SMPTE ST 2082-12(12G Quad 8K)	4320p(60/59.94/50)
	SMPTE ST 2082-10(12G Single)	2160p(60/59.94/50/30/29.97/25/24/23.98)
	SMPTE ST 2081-11(6G Dual)	2160p(60/59.94/50)
	SMPTE ST 2081-10(6G Single)	2160p(30/29.97/25/24/23.98)
	SMPTE ST 425-AB	1080p(60/59.94/50/30/29.97/25/24/23.98/30sF/29.97sF /25sF/24sF/23.98sF) / 1080i (60/59.94/50)
	SMPTE ST 274	1080p(30/29.97/25/24/23.98/24sF/23.98sF)
		1080i (60/59.94/50)
	SMPTE ST 296	720p(60/59.94/50)
	SMPTE ST 260	1920 x 1035i(60/59.94)
	SMPTE ST 2048	2048 x 1080p(24/23.98/24sF/23.98sF)
	HDMI 2.0	~ 2160p(60)
	SFP	12Gbps, 6Gbps, 2.970Gbps, 1.485Gbps, 270Mbps
Audio In/Out	1 x Phone Jack In	Line In(Stereo)
	1 x Phone Jack Out	H/P Out(Front, Stereo)
	2 x Speaker Out	Stereo
Display	Size	23.74" LCD
	Resolution	3840 x 2160 (16:9)
	Pixel Pitch	0.1369mm
	Color	1.073B Colors, 10Bit
	Viewing Angle	178(H), 178(V)
	Luminance of White	540cd/m <sup>2</sup> (HDR Maximum 400cd/m <sup>2</sup> )
	Contrast	1200 : 1
	Display Area (H x V)	525.65 x 295.70 (mm)
General	2 x Ethernet	Control/Update, RJ-45P Input / Output
	1 x GPIO	GPI-7 Port, RJ-45P Jack
	2 x Serial	RS-422 Jack, RJ-45P Input / Output
	1 x USB	For Firmware Update, Color Calibration
	Power Requirements	AC(100-230V, 50/60Hz)/DC 24V
	Power Consumption	80W
	Operating Temperature	0°C ~ 40°C(32°F~104°F)
	Operating Humidity	20% ~ 80% RH
	Weight	10.5kg / 23.14lbs
	Dimensions (WxHxD)	605 x 400 x 140mm
		23.81 x 15.74 x 5.51inch
	Accessories	Power Cable
Option	Rack Mount Kit/ Carrying Case	

\* Specifications are subject to change without prior notice for the product quality improvement.



## Specifications (OBM-U310Q)

ITEM		OBM-U310Q
Input	4 x BNC	12G/6G/3G/HD
	1 x HDMI	HDMI 2.0
	2 x SFP	SFP
Output	4 x BNC	12G/6G/3G/HD/4 Active Loop Output
Input Signal Format	SMPTE ST 2082-12(12G Quad 8K)	4320p(60/59.94/50)
	SMPTE ST 2082-10(12G Single)	2160p(60/59.94/50/30/29.97/25/24/23.98)
	SMPTE ST 2081-11(6G Dual)	2160p(60/59.94/50)
	SMPTE ST 2081-10(6G Single)	2160p(30/29.97/25/24/23.98)
	SMPTE ST 425-AB	1080p(60/59.94/50/30/29.97/25/24/23.98/30sF/29.97sF /25sF/24sF/23.98sF) / 1080i (60/59.94/50)
	SMPTE ST 274	1080p(30/29.97/25/24/23.98/24sF/23.98sF)
		1080i (60/59.94/50)
	SMPTE ST 296	720p(60/59.94/50)
	SMPTE ST 260	1920 x 1035i(60/59.94)
	SMPTE ST 2048	2048 x 1080p(24/23.98/24sF/23.98sF)
	HDMI 2.0	~ 2160p(60)
	SFP	12Gbps, 6Gbps, 2.970Gbps, 1.485Gbps, 270Mbps
Audio In/Out	1 x Phone Jack In	Line In(Stereo)
	1 x Phone Jack Out	H/P Out(Front, Stereo)
	2 x Speaker Out	Stereo
Display	Size	32" LCD
	Resolution	3840 x 2160 (16 : 9)
	Pixel Pitch	0.1845mm
	Color	1.073B Colors, 10Bit
	Viewing Angle	178(H), 178(V)
	Luminance of White	1000cd/m <sup>2</sup> (HDR Maximum 700cd/m <sup>2</sup> )
	Contrast	1500 : 1
	Display Area (H x V)	708.48 x 398.52 (mm)
General	2 x Ethernet	Control
	1 x GPIO	GPI-7 Port, RJ-45P Jack
	2 x Serial	RS-422 Jack, RJ-45P Input / Output
	1 x USB	For Firmware Update, Color Calibration
	Power Requirements	AC(100-230V, 50/60Hz)/DC 24V
	Power Consumption	120W
	Operating Temperature	0°C ~ 40°C(32°F~104°F)
	Operating Humidity	20% ~ 80% RH
	Weight	Main Body : 14.8kg / 32.62lbs
	Dimensions (WxHxD)	762 x 512 x 190mm (with stand)
		30 x 20.15 x 7.48inch
	Accessories	Power Cable
	Option	Wall Mount Kit/ Carrying Case

\* Specifications are subject to change without prior notice for the product quality improvement.

## Specifications (OBM-U420Q)

ITEM		OBM-U420Q
Input	4 x BNC	12G/6G/3G/HD
	1 x HDMI	HDMI 2.0
	2 x SFP	SFP
Output	4 x BNC	12G/6G/3G/HD/4 Active Loop Output
Input Signal Format	SMPTE ST 2082-12(12G Quad 8K)	4320p(60/59.94/50)
	SMPTE ST 2082-10(12G Single)	2160p(60/59.94/50/30/29.97/25/24/23.98)
	SMPTE ST 2081-11(6G Dual)	2160p(60/59.94/50)
	SMPTE ST 2081-10(6G Single)	2160p(30/29.97/25/24/23.98)
	SMPTE ST 425-AB	1080p(60/59.94/50/30/29.97/25/24/23.98/30sF/29.97sF /25sF/24sF/23.98sF) / 1080i (60/59.94/50)
	SMPTE ST 274	1080p(30/29.97/25/24/23.98/24sF/23.98sF)
		1080i (60/59.94/50)
	SMPTE ST 296	720p(60/59.94/50)
	SMPTE ST 260	1920 x 1035i(60/59.94)
	SMPTE ST 2048	2048 x 1080p(24/23.98/24sF/23.98sF)
	HDMI 2.0	~ 2160p(60)
	SFP	12Gbps, 6Gbps, 2.970Gbps, 1.485Gbps, 270Mbps
Audio In/Out	1 x Phone Jack In	Line In(Stereo)
	1 x Phone Jack Out	H/P Out(Front, Stereo)
	Speaker Out	-
Display	Size	42.5" LCD
	Resolution	3840 x 2160 (16:9)
	Pixel Pitch	0.2451mmx0.2451mm
	Color	1.07Billion Colors(True 10bit)
	Viewing Angle	178(H), 178(V)
	Luminance of White	700cd/m <sup>2</sup> (HDR Maximum 400cd/m <sup>2</sup> )
	Contrast	1000 : 1
	Display Area (H x V)	941.184 x 529.416 (mm)
General	2 x Ethernet	Control/Update, RJ-45P Input / Output
	1 x GPIO	GPI-7 Port, RJ-45P Jack
	2 x Serial	RS-422 Jack, RJ-45P Input / Output
	1 x USB	For Firmware Update, Color Calibration
	Power Requirements	AC(100-230V, 50/60Hz)
	Power Consumption	150W
	Operating Temperature	0°C ~ 40°C(32°F~104°F)
	Operating Humidity	20% ~ 80% RH
	Weight	32kg / 70.54lbs
	Dimensions (WxHxD)	990 x 639 x 210 mm
		38.97 x 25.15 x 8.26inch
	Accessories	Power Cable
	Option	Wall Mount Kit/ Carrying Case

\* Specifications are subject to change without prior notice for the product quality improvement.



**POSTIUM KOREA** Co., Ltd.

208, Building A, Samsung Techno Valley, 140, Tongil-ro,  
Deogyang-gu, Goyang-si, Gyeonggi-do, Korea, 10594

Tel : +82.2.354.6055 / Fax : +82.2.354.6056

E-mail : [sales@postium.com](mailto:sales@postium.com)

[www.postium.com](http://www.postium.com)